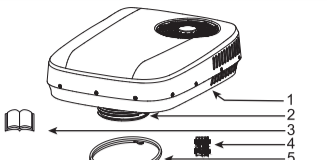
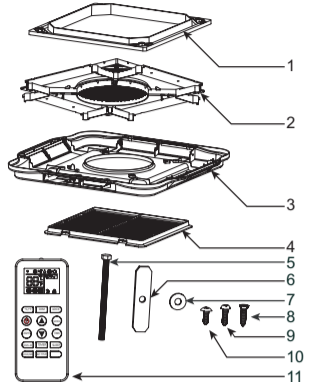

## 2 Packing List

Outdoor unit		Qty
	1. AEOLUS air-conditioner outdoor unit	1
	2. Air inlet duct	1
	3. Manual	1
	4. Terminal block	1
	5. Connecting power cable 8 AWG	6m
Indoor unit		Qty
	1. Roof mount	1
	2. Plenum mounting bracket	1
	3. Plenum assembly	1
	4. Return air filter	1
	5. M8 x 120 mm hex head bolt	4
	6. Metal clamping bar	4
	7. Large M8 washer	4
	8. Countersunk head self-tapping screw	10
	9. Plenum screw - ST4x19 pan head screw	8
	10. Truss head tapping screw	4
	11. Remote control & bracket	1

## 3 Installation Guidance

### Installation instructions

- Read this Manual thoroughly before installation and understand the guidance.
- Do not add other parts or restructure the product in the installation.
- Consult with HOUGHTON or the local distributor in the case of unusual applications or installation conditions that are not specifically covered by this manual.

### Installation requirements

- The RV or caravan roof shall be able to support the air-conditioner's weight.
- Minimum thickness of roof is 25mm; maximum thickness of roof is 70mm.
- If the roof's thickness is greater than 70mm, you can purchase a "Thick roof kit" to suit your unit from HOUGHTON or the local distributor.

### 3.1 Installation position

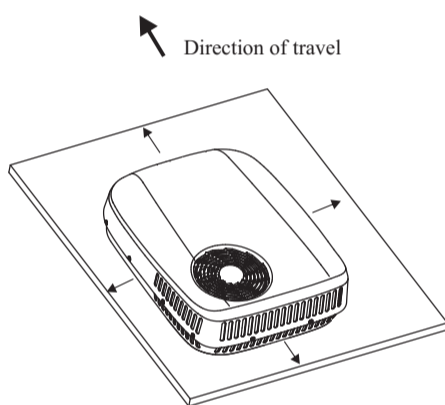

Before the installation, consider the installation position:

- The air-conditioner outdoor unit should be installed at the center of the roof to ensure even air distribution.
- The installation position of the outdoor unit shall be consistent with the traveling direction of the caravan.
- Before installing ensure that there is sufficient room for the plenum assembly to be installed.
- Consider the installation position and ensure that outlets are at least 400mm away from cupboards, walls & bulkheads that can redirect conditioned air back to the return air intake. If an outlet is closer than 400mm from an obstruction, then it should be sealed closed. Failure to do this will result in a unit that frequently cycles on and off.

360x360mm (400x400mm) cutting position shall avoid roof cladding joints where ever possible.

#### NOTE

- There shall be a space of 100mm minimum all around the roof top unit to ensure suitable air flow and access for maintenance.

Measures in mm.

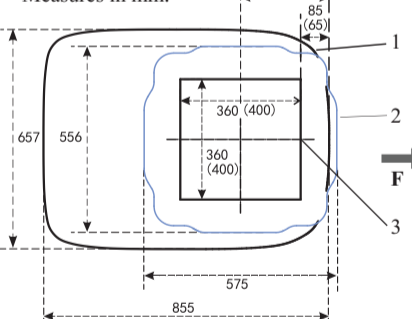

The figure below shows the foot print of the AEOLUS air-conditioner and the plenum installation. Measure from the reference position of the 360x360mm (400x400mm) square hole. Remember to add 100mm clearance around roof top unit perimeter.

#### NOTE

- Angle of inclination of the air-conditioner shall not be larger than 5° and the back part of the air-conditioner shall not be higher than the front part.
- For advice on installations outside of these limits please contact with HOUGHTON or the local distributor.

### 3.2 Load bearing of roof

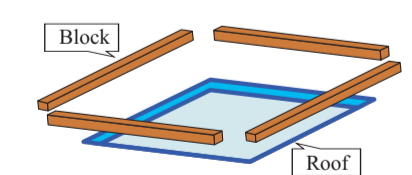

The roof shall be able to bear the weight of the air-conditioner and shall be level without accumulating water. It is suggested that the caravan manufacturer confirms the suitability of the roof for load bearing.

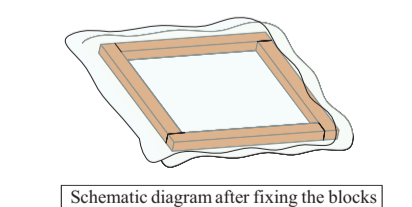

If the installation hole is not preexisting then consult your caravan manufacturer for the most suitable way to cut the installation hole.

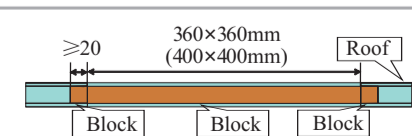

The 360x360mm(400x400mm) hole shall be boarded up with wood sections that are at least 20mm thick. This boarding is to ensure that the roof will not crush from the installation bolts and that air conditioned air does not enter the ceiling space.

### 3.3 Power supply

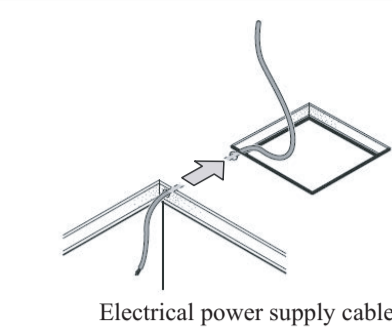

### 3.4 Installation of roof mount

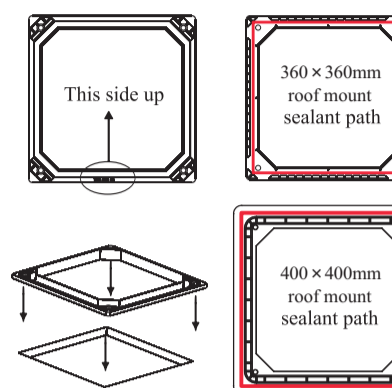

- Make sure the roof is clean and dry and free from oil or grease.
- Confirm orientation by starting with the "This side up" logo upwards.
- Turn the part over and apply the self-leveling RV Roof sealant uniformly over the path shown.
- Turn the part over again and make sure "This side up" is up. Press down firmly over the installation hole and remove any sealant that has squeezed out to form an effective seal.

**Important** - do not run sealant inside the mounting bolt holes. This will cause breaks in the seal. Always run the sealant around the outside of the bolt holes as shown.

### 3.5 Installation of outdoor unit

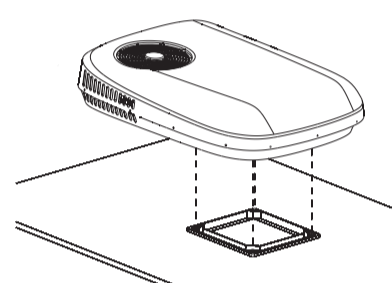

- Remove the outdoor unit from the carton and move it to the installation position on the roof.
- Put the outdoor unit over the previously installed roof mount. Adjust the position to make sure they mate and the four bolt holes in the corners align.

#### NOTE

- The outdoor unit is heavy. Always have a second person to help carrying the unit.
- Use the M8 bolts and check if the holes are aligned with the holes of the plenum mounting bracket. If not then use a long screw driver inserted up through the two holes to assist with alignment.

### 3.6 Connect the power supply and 485 communication

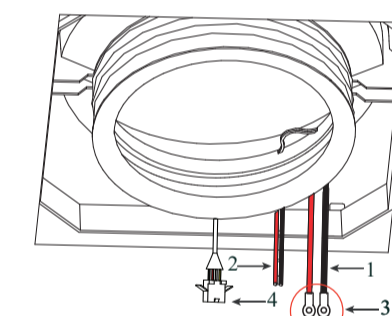

- Power connection cable
- 485 communication cable (If available)
- OT terminal block
- Outdoor unit butt plug

It is the installers responsibility to ensure that local wiring regulations are followed.

- Look upward from inside the caravan, there are heavy gauge red black power connection cables. Connect the power connection to the large terminal block provided.

- Connect the external electrical power supply cable to the large terminal block and note the positions of the "+" pole and "-" pole.

- Look upward from inside the caravan, there are light gauge red and black 485 communication cable. Connect the 485 communication cables to the small terminal block. (If available)

- Connect the external 485 communication cables to the small terminal block and note the positions of the "+" pole and "-" pole. (If available)

Supply cord is type Y statement. Any replacement of such supply cord is intended to be made by the manufacturer, its service agent or similar qualified person. When connecting power supply, the appliance requires a circuit breaker (50A) to disconnect power supply after installation.

### 3.7 Installation of the plenum mounting bracket

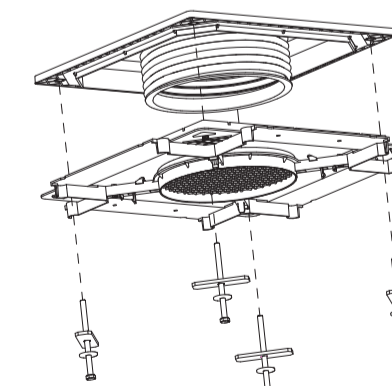

- Connect M8 bolts, washers and fixing metal plates in order shown.
- Lift the plenum mounting bracket toward the air conditioner.
- Insert M8 bolts, washers and metal clamping bars into the 4 corner holes of the plenum mounting bracket. Screw the bolts into their receiving threads by hand to ensure engagement.

- Ensure all bolts have started correctly for at least 2 or 3 rotations to avoid cross threading.
- Ensure the metal clamping bars align with the corresponding recess in the plenum mounting bracket as the bolts are tightened.
- Evenly tighten up all four bolts.

#### NOTE

- Tighten the bolts to 5-7 Nm torque.
- Do not exceed 7Nm(5.2 lbf ft).

### 3.8 Connection of air inlet duct

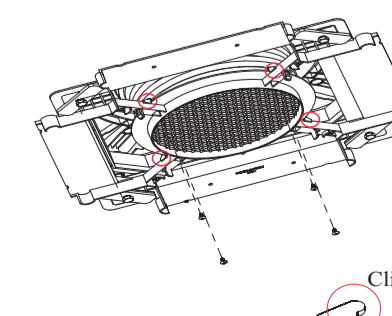

- Grasp the free end of the air inlet duct and pull it down until it touches the plenum mounting bracket.
- Continue to pull the rim of the duct down until it engages with the four latches on the plenum mounting bracket.
- The duct is correctly connected when you hear the four distinct clicking sounds of the latches and the rim of the duct is parallel to the surface of the bracket.
- If required to fix the rim with the plenum mounting bracket using 4 ST4x10 truss head tapping screws.

### 3.9 Installation of the plenum assembly

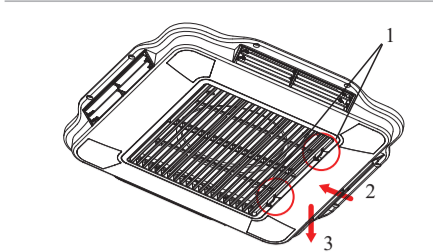

- Remove the air filter from the plenum by pushing both tabs inwards and then downwards.

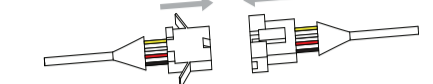

- Connect the socket and plug of the display panel and outdoor unit.
- Note that colors of the wires match: yellow to yellow, red to red, etc.

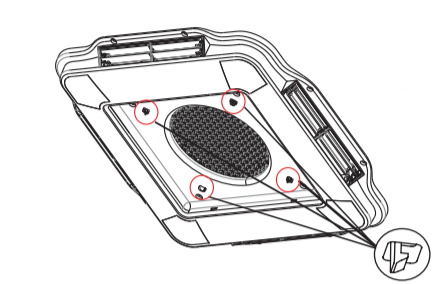

- Attach the plenum assembly to the plenum mounting bracket by engaging the two parts.

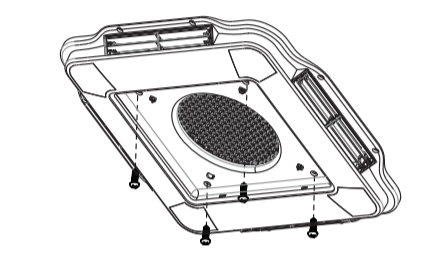

- Fix the plenum assembly on the plenum mounting bracket with four ST4x19 pan head screws.

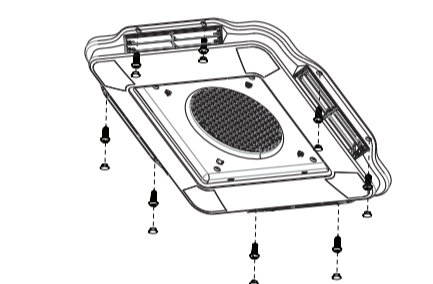

- Remove the screw caps from around the perimeter of the plenum.
- Fix the plenum to the ceiling using the 8 countersunk head screws.
- Replace the screw caps to the plenum.

#### NOTE

- This section is not compulsory but may be used to pull the plenum up to the ceiling and remove any gaps.

### 3.10 Installation of the air filter

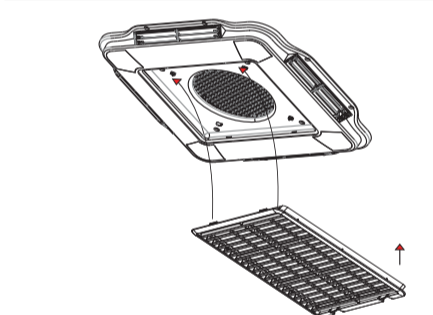

- Install the air filter as shown:
- Insert the two large tabs into the corresponding slots.
- Move the filter upwards and make sure the tabs engage.

### 3.11 Holder remote control

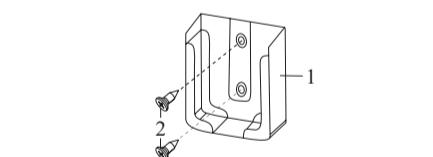

- Install the holder for the remote control in a

### Adjust the louver

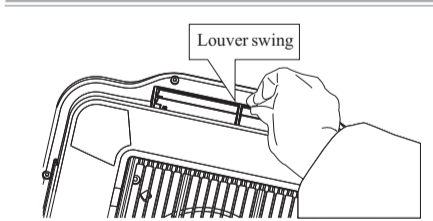

- Adjust direction and angle of louver by moving blade around its axis. The 2 blades move together. Louvers on opposite sides are symmetrical.
- This installation is all completed.**

## 4 Quick Start Guide

- STEP 1**  
Connect the 48V battery pack and note the positions of the "+" pole and "-" pole. It is recommended to add a power control switch to facilitate disconnection and connection.

#### NOTE

- Follow all local wiring standards and recommended best practice guidelines.
- Ensure correct polarity of power supply connection to the unit.
- Electrical connections to terminal blocks must be firm but not overtightened.
- Ensure power supply can be isolated and is protected with appropriate breaker or fuse to protect cabling.

- STEP 2**  
Using the remote control, start the air-conditioner by pressing "ON" button and then select fan function by pressing the "MODE" button.

- STEP 3**  
Operate in low FAN, medium FAN and high FAN in turn to check normal operation.

- STEP 4**  
Select COOL/HEAT mode, adjust the set point temperature to three degrees lower/higher than the room temperature, the unit will start to blow cool/warm air after the compressor starts.

## 5 Remote control operation

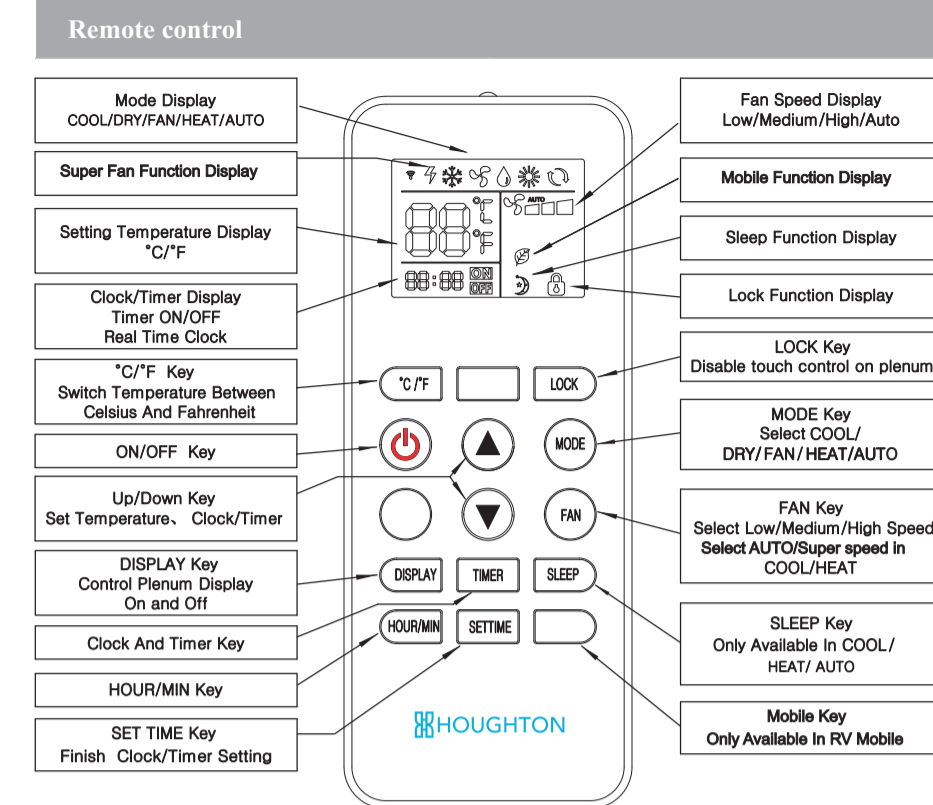

### Plenum display



Display description of plenum:

- Touch screen key
- Mode display
- Temperature display (temperature range: 16°C—30°C)

- You can control the basic functions of the air-conditioner with the touch screen key on the plenum display. This is useful if the remote control is lost or does not function.
- Press the touch screen key at the plenum. With each touch you cycle through the modes:



- Cooling only air-conditioner skip heat mode.
- In case the plenum touch screen key are locked by the remote controller, operations of the key would be not available. Press the lock key on the remote controller again to unlock!
- If the touch screen key is not responding check that the screen is not locked. Press LOCK key on remote control and try again.

### 5.1 Switching the unit ON/OFF

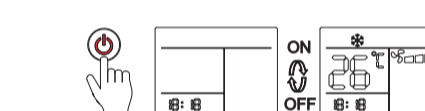

- Press the on/off "ON/OFF" key, the machine turns on, the buzzer of the plenum beeps once and the running mode and temperature will be displayed.
- Press the on/off "ON/OFF" key again, unit turns off and the plenum display will be blank.

### 5.2 FAN mode

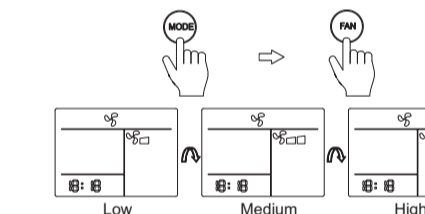

- Press the "MODE" key, select the "FAN" mode.
- Press the "FAN" key to Select Low/Medium/High FAN. The plenum will display "FAN" and room temperature.

### 5.3 COOL mode

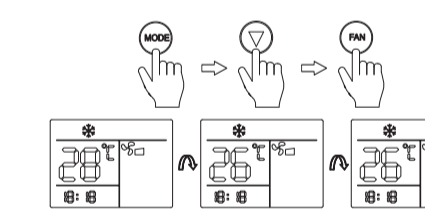

- Press the "MODE" key, select the "COOL" mode.
- Press the down "DOWN" key to set a temperature lower than the room temperature.
- Press the "FAN" key to select AUTO/Low/Medium/High/Super speed and the plenum will display "COOL" and the set temperature.

### 5.4 DRY mode

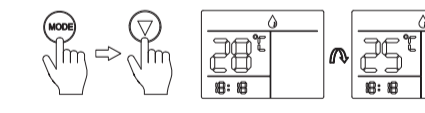

- Press the "MODE" key, select the "DRY" mode.
- Press the down "DOWN" key to set the temperature 1°C lower than the room temperature and the plenum will display "DRY" and the set temperature.

### 5.5 HEAT mode (Cooling only air-conditioner skip heat mode)

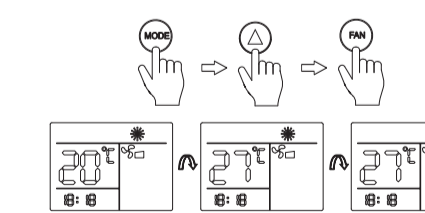

- Press the "MODE" key, select the "HEAT" mode.
- Press the up "UP" key to increase the room temperature.
- Press the "FAN" key to select AUTO/Low/Medium/High/Super speed and the plenum will display "HEAT" and the set temperature.

#### NOTE

- When operating in heating mode in low ambient temperatures the unit will periodically defrost the outside heat exchanger. The plenum will display "dF" during defrosting and then return to heating once the defrost is completed.

### 5.6 AUTO mode (Cooling only air-conditioner skip heat mode)

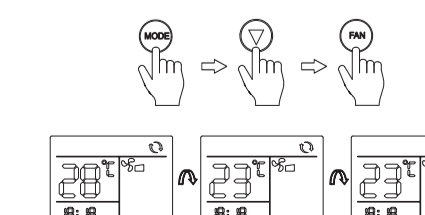

- Press the "MODE" key, select the "AUTO" mode.
- Press the up "UP" or down "DOWN" key to adjust the set temperature.
- Press the "FAN" key to select Low/Medium/High speed and the plenum will display "AUTO" and "FAN" or "COOL" and "HEAT" and the setting temperature.

### 5.6 AUTO mode (Cooling only air-conditioner skip heat mode)

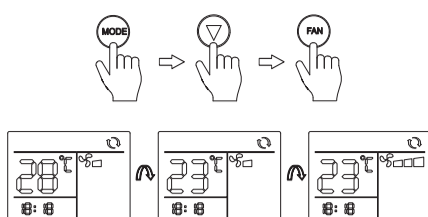

- Press the "MODE" key, select the "☺" mode.
- Press the up "▲" or down "▼" key to adjust the set temperature.
- Press the "FAN" key to select Low/Medium/High speed and the plenum will display "☺" and "☼" or "☽" and "☿" and the setting temperature.

### 5.7 SLEEP mode

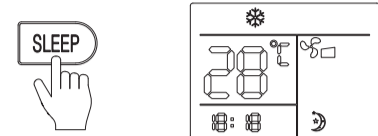

- In the COOL/HEAT mode, press the "SLEEP" key to enter the sleep mode.
- Press the up "▲" or down "▼" key to adjust the set temperature.
- Press the "SLEEP" key again, exit from the sleep mode.

#### NOTE

- The sleep mode can be entered only in COOL / HEAT / AUTO mode. Fan speed default low speed can not be adjusted.

### 5.8 Use the air conditioner on road

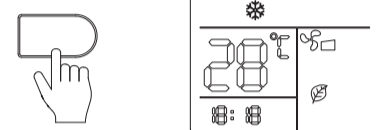

- To use the air conditioner on road, press the "☺" key on the remote control, the display on the remote control will display the "☺" symbol. In this setting, the outdoor fan speed will be set at Turbo to ensure the air flow of outdoor fan. This set is only available in operation mode COOL, HEAT or DRY mode.

### 5.9 Setting the clock

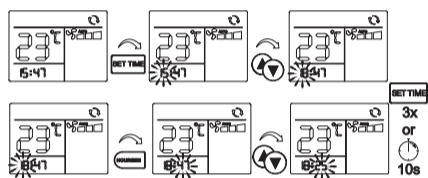

- Press the "SET TIME" key so that the hours digits are flashing.
- Press the up "▲" or down "▼" key to set the hour.
- Press the "HOUR/MIN" key so that the minute digits are flashing.
- Press the up "▲" or down "▼" key to set the minutes.
- To end the setting mode press the "SET TIME" key 3 times or wait 10 seconds until the digits stop flashing.

### 5.10 Setting the ON / OFF timers

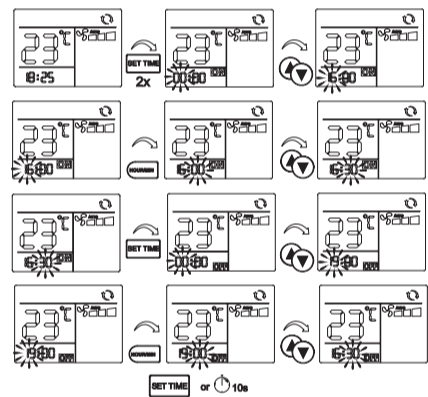

- The timer can be set to start and stop the unit at a preprogrammed time.
- Press the "SET TIME" key twice until ON shows on the upper right side of the clock and the hour digits are flashing.
  - Press the up "▲" or down "▼" key set the hour when the unit should switch ON.
  - You may also set the minutes by pushing the "HOUR/MIN" key and using the UP or DOWN keys.
  - Press the "SET TIME" key again until OFF shows on the lower right side of the clock and the hour digits are flashing.
  - Press the up "▲" or down "▼" key to set the hour when the unit should switch OFF.
  - You may also set the minutes by pushing the "HOUR/MIN" key and using the UP or DOWN keys.
  - To end the setting mode press the "SET TIME" key again or wait 10 seconds until the digits stop flashing. The clock time is shown.

#### NOTE

- The timer ON and OFF times are now set but not yet activated.

### 5.11 Activating the timer

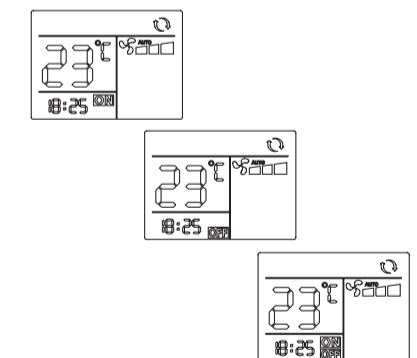

- Before activating the timer, select the operation mode, the set temperature and the desired fan level. After the set and stop times are set (see chapter 5.9) one of the three different TIMER modes can be activated:
- TIMER ON mode: In this mode the unit will switch on at the desired ON time and keep on running.
- TIMER OFF mode: In this mode the unit will stop running at the desired OFF time and will stay off.
- TIMER ON/OFF mode: In this mode the unit will start to run at the ON time and stop running at the OFF time.

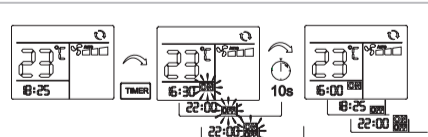

- Press the "TIMER" key repeatedly until either the ON or OFF or both symbols are flashing depending on which timer mode is preferred. To confirm the selection wait 10 seconds until the symbol stops flashing and lights up permanently. The clock time shows again.
- To cancel timers press TIMER until neither ON or OFF are displayed.

### 5.12 Celsius and Fahrenheit degree change

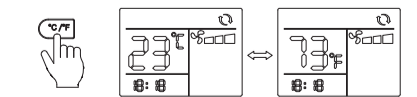

- In any mode, press the "C/F" key, you can select temperature units between Celsius and Fahrenheit.

## 6 Product Maintenance

#### Filter

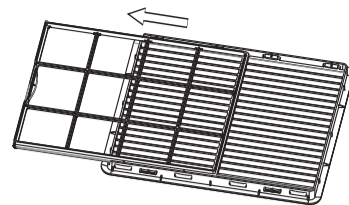

Replacement filters can be ordered separately.

#### Bolt check

- It is recommended that the bolts holding the unit to the roof are checked for tightness 3 months after the first installation of the product.
- These bolts should be regularly inspected every 12 months throughout the air-conditioners life.

#### Maintenance

- The return air filters are the only components that need to be maintained periodically.
- Check and clean the filters each week when in use to prevent the filters from being blocked by dirt and lint.
- The filters should be washed frequently to ensure effective cooling and heating.
- Pull out the filter from the plenum before washing in warm water with a touch of detergent.
- It is recommended that the air-conditioner is operated regularly to ensure good performance.
- In the case of a caravan that will not be used regularly then the unit should be operated for 20-30 minutes every 6 months.

## 7 Specifications

Parameter	AEOLUS H2800	Parameter	AEOLUS H2800
Power supply	48V	Maximum current	30.3 A
Cooling capacity	2600(1700-2800) W	Maximum design pressure	4500 kPa
Power input cooling	1200(790-1260) W	Minimum design pressure	3000 kPa
Current cooling	24.8(16.5-26.2)A	Maximum air flow	480 m <sup>3</sup> /h
Heating capacity	2400(1600-2500)W	Weight outdoor unit	net 30 kg
Power input heating	1050(660-1120)W	Weight indoor unit	net 3 kg
Current heating	21.8(13.8-23.3)A	Refrigerant charged	R410A/680 g
Maximum input power	1450W		
Outdoor unit dimension	Height: 215mm	Width: 657mm	Length: 855mm
Indoor unit dimension	Height: 49mm	Width: 556mm	Length: 575mm

#### NOTE

- All parameters listed are subject to change without notice and the specifications shown on the unit data plates shall prevail.
- E&OE All values are approximate & subject to change.
- Rated cooling test condition: indoor 27°C/19°C outdoor 35°C/24°C.
- Rated heating test condition: indoor 20°C/12°C outdoor 7°C/6°C.

## 8 Trouble Shooting Guide

Symptom	Remedy
No plenum display when ON/OFF is pressed	<ul style="list-style-type: none"> <li>➢ Check power supply is OK?</li> <li>➢ Check whether the remote battery is OK?</li> <li>➢ Check whether the remote control is off?</li> <li>➢ Check whether the battery is too low voltage or damaged?</li> <li>➢ Poor connecting of the control line between the outdoor unit and the plenum, maybe fallen off.</li> </ul>
Cooling not available.	<ul style="list-style-type: none"> <li>➢ Check that the cooling mode is selected and the plenum display shows "☺".</li> <li>➢ Use the remote control to set required temperature below the current room temperature.</li> <li>➢ The compressor will delay a re-start for three minutes.</li> </ul>
Heating not available.	<ul style="list-style-type: none"> <li>➢ Check that the heating mode is selected and the plenum display shows "☼".</li> <li>➢ Use the remote control to set required temperature above the current room temperature.</li> <li>➢ More time would be needed for starting heating under extremely cold condition.</li> <li>➢ When the unit is in heating mode and the outside temperature is very low the unit may automatically enter defrost mode. The heating will temporarily stop as the unit warms the outside coil to remove any frost ice. Heating will resume once the outside coil has been cleared. During defrost the unit will display "dF".</li> </ul>
Poor cooling capacity.	<ul style="list-style-type: none"> <li>➢ Check and clean return air filter.</li> <li>➢ Turn on the fan to high FAN to obtain the maximum capacity.</li> <li>➢ Make sure the air duct is installed in place.</li> <li>➢ Make sure all the doors and windows, as well as the sunroof are closed.</li> <li>➢ Curtains and awnings can be used to decrease the heating load.</li> </ul>
Multiple air-conditioners fail to realize centralized control. If centralised control is not offered with these units then remove this reference.	<ul style="list-style-type: none"> <li>➢ Ensure that each air-conditioner operates normally separately.</li> <li>➢ Ensure 485 communication lines of multiple air conditioners are connected with each other.</li> <li>➢ Ensure that each air-conditioner is equipped with a unique address.</li> </ul>

#### Fault codes displayed on the panel

E0	Motherboard and display board communication fault
E1	Room temperature sensor fault
E2	Indoor coil temperature sensor fault
E3	Indoor DC fan fault
E5	Poor performance
0E	Outdoor ambient temperature sensor fault
1E	Outdoor coil temperature sensor fault
2E	Discharge sensor fault
4E	Outdoor DC fan fault
5E	DC voltage overvoltage protection
6E	DC voltage undervoltage protection
7E	Compressor stall protection
8E	Compressor locked rotor protection
9E	Compressor phase current software current protection
AE	Compressor phase current hardware current protection
bE	Communication fault between electric control board and compressor drive board
Lo	Low voltage warning

#### NOTE

- Before contacting Houghton for technical support please collect the following information.
- Are any error codes displayed?
  - Is the display panel in normal operation or not? Does it display a temperature from 16 to 30°C?
  - Can you adjust the setting temperature when in cool or heat mode?
  - Is there a "0" shown in the display?
  - Is the display showing a jumbled display?
  - When in fan mode is there any air flow from the plenum outlets?
  - Can you hear the compressor starting or stopping in heating or cooling mode?
- Your help in collecting this information will greatly assist the Houghton service team in correcting any problems-Thank you.

## 9 Circuit Diagram

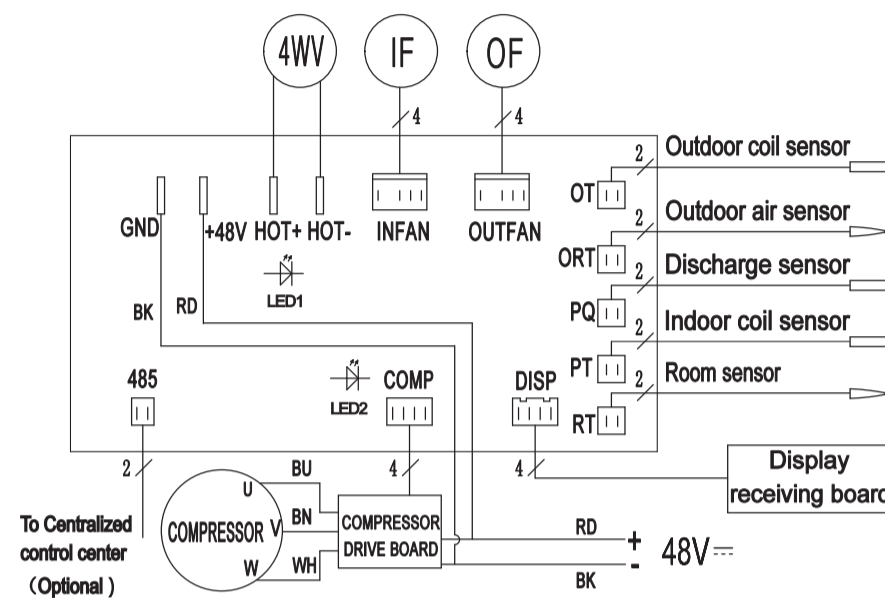

#### CSA

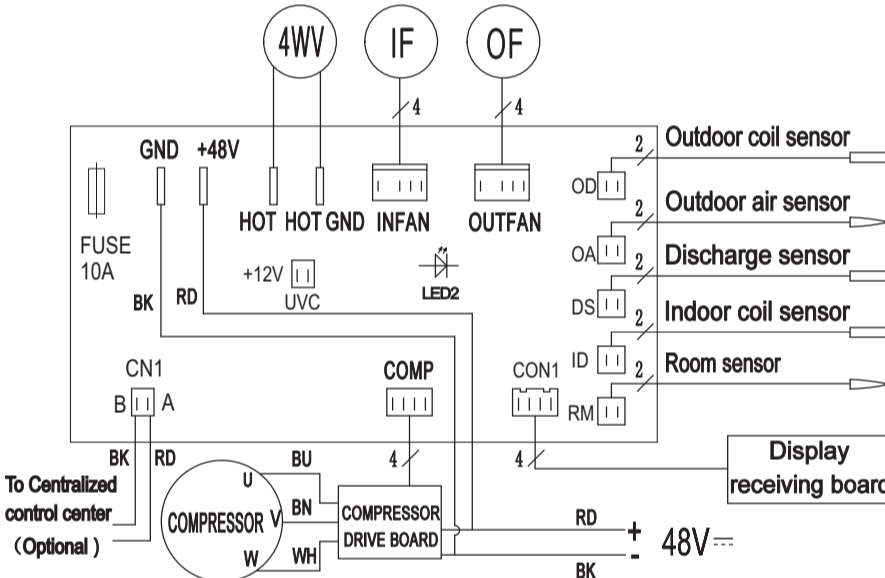

## 10 Disposal

- Dispose of packaging material as required by local regulations, separating them for recycling.
- The system contains synthetic green house gas R410A and cannot be disposed off as regular waste.
  - Dispose the system according to the local applicable rules and regulations. Obtain information about disposal at the city council, the responsible waste station and/or your local sales partner.

**HOUGHTON**

MODEL NUMBER: \_\_\_\_\_

SERIAL NUMBER: \_\_\_\_\_

DATE PURCHASED: \_\_\_\_\_

## OWNERS MANUAL 48VDC VEHICLE INVERTER AIR-CONDITIONER

## AEOLUS

MODEL

H2800



The air-conditioner is a parking air-conditioner and cannot be operated in vehicles while driving.



For your safety, please read this manual carefully before using the product.

7498-2000-01-V2

## 1 Safety

	Explanation
⚠	All the contents with this "Warning" logo are about the safety of the product and the user. The user shall operate in strict compliance with the instructions.
🚫	All the contents with this "Prohibition" logo are about the actions that shall be prohibited, or else the machine may be damaged or the user's personal safety may be endangered.

- ⚠ If you are not to use the air-conditioner for a long time, please isolate the power supply.
- ⚠ Clean the filter of the air-conditioner regularly. A dirty filter will decrease air flow and lead to poor cooling performance.
- ⚠ Use the remote control to operate the air-conditioner.
- ⚠ Install the air-conditioner in compliance with the instructions of this manual.
- ⚠ Incorrect installation methods or alteration of the product may cause damage to the product or personal injuries to the user.
- ⚠ Be careful when installing the unit on the roof of the caravan, crawl boards may be required.
- ⚠ There may be wires between the roof and the ceiling. When cutting into the roof, make sure the power is isolated to prevent risk of electric shock.
- ⚠ Installation and maintenance of the air-conditioner must only be performed by personnel with appropriate trade qualifications and holding current licenses for such work.
- ⚠ Do not over-tighten the power connection terminals.
- ⚠ Ensure that your electrical supply and wiring is correctly sized for the power demand of the air-conditioner.
- ⚠ This appliance is not intended for use by persons (including children) with reduced physical, sensory or mental capabilities, or lack of experience and knowledge, unless they have been given supervision or instruction concerning use of the appliance by a person responsible for their safety. Children should be supervised to ensure that they do not play with the appliance.
- ⚠ Ensure the voltage range is 45V ~ 60V, otherwise the air conditioner will be damaged. The electrical power supply cable must be at least 8 AWG or thicker and the communication cable must be at least 18 AWG. Cable gauge must be sufficient to take full load current over the cable length.

- 🚫 Keep the air inlet and outlet of the inside and outside units of the air-conditioner clear.
- 🚫 Do not spray any paint or insecticide on the surface of the air-conditioner.
- 🚫 Immediately turn off the air-conditioner and isolate power supply if there is any unusual odour, smoke or fire detected. Contact after-sales service personnel in case of unit fault and fire.