



MODEL NUMBER: _____

SERIAL NUMBER: _____

DATE PURCHASED: _____

OWNERS MANUAL

CARAVAN AIR-CONDITIONER

BELAIRE

MODEL

H2800



For your safety, please read this manual
carefully before using the product.

Safety Notices

Dear user, thank you for choosing a HOUGHTON caravan air-conditioner. For your ease of use and safe maintenance we have included the following symbols in this manual:

 All the contents with this "Warning" logo are about the safety of the user and the air-conditioner. The user shall operate in strict compliance with the instructions.

 All the contents with this "Prohibition" logo are about the actions that shall be prohibited, or else the air-conditioner may be damaged or the user's personal safety may be endangered.

Table of Contents

Safety Notes.....	1
Product Introduction.....	2
Packing List.....	3
Installation Guidance.....	4
Quick Start Guide.....	10
Remote control operation.....	11
Product Maintenance.....	17
Specifications.....	18
Exploded Diagram and Parts List.....	19
Trouble Shooting Guide.....	21
Circuit Diagram.....	22

Safety Notes

- ⚠ Make sure the external electric supply socket of the caravan air-conditioner is effectively grounded in accordance with your local regulations.
- ⚠ Failure to ground the unit correctly may cause electric shock or fire.
- ⚠ The caravan air-conditioner shall be switched on for electric leakage detection after installation.
- ⚠ If you are not to use the air-conditioner for a long time, please isolate the power supply.
- ⚠ Clean the filter of the air-conditioner regularly. A dirty filter will decrease air flow and lead to poor heating and cooling performance.
- ⚠ Use the remote control to operate the air-conditioner.
- ⚠ Install the air-conditioner in compliance with the instructions of this manual.
- ⚠ Incorrect installation methods or alteration of the product may cause damage to the product or personal injuries to the user.
- ⚠ Be careful when installing the unit on the roof of the caravan, crawl boards may be required.
- ⚠ There may be wires between the roof and the ceiling. When cutting into the roof, make sure the power is isolated prevent risk of electric shock.
- ⚠ Installation and maintenance of the air-conditioner must only be performed by personnel with appropriate trade qualifications and holding current licenses for such work.
- ⚠ Do not over-tighten the power connection terminals.
- ⚠ Ensure that your electrical supply and wiring is correctly sized for the power demand of the air-conditioner. Refer to the product specifications.
- ⚠ This appliance is not to be used by persons (including children) with reduced physical, sensory or mental capabilities, or lack of experience and knowledge. Children are not to play with this appliance and should be supervised at all times.
- ⚠ It may not be operated in vehicles while driving.
- ⚠ Only connect the LED lighting system to the DC power lead provided from the air-conditioner. Connection to any other power supply may damage the LED lights.
- ⚠ Means for disconnection must be incorporated in the fixed wiring in accordance with the wiring rules.

- ⊘ Keep the air inlet and outlet of the inside and outside units of the air-conditioner clear.
- ⊘ Do not spray any paint or insecticide on the surface of the air-conditioner.
- ⊘ Immediately turn off the air-conditioner and isolate power supply if there is any unusual odour, smoke or fire detected. Contact after-sales service personnel in case of unit fault and fire.

Product Introduction

A. Purpose

HOUGHTON BELAIRE is designed to provide a comfortable environment inside a recreational vehicle or caravan.

B. Achieving effective heating & cooling

Many factors will affect the total heat load within the caravan and many factors can also affect the working efficiency of the air-conditioner. Before purchasing HOUGHTON BELAIRE air-conditioners, the user shall consult with the caravan manufacturer to understand the total heat load of the caravan and to choose the correct air-conditioner for the application.

The following measures are very useful to reduce the heat load within a caravan or RV and improve the performance of the air-conditioner.

- Close all the doors, skylights and windows, draw the curtains and open the sunshade or awning.
- Adjust the caravan's position to make sure the sunshade is on the southern side in the northern hemisphere or on the northern side in the southern hemisphere. This will reduce the exposure to direct sunshine.
- Turn off unnecessary electrical appliances within the caravan to reduce the heat load.
- Cook outside of the caravan when possible.
- Park the caravan in shade if possible.
- In case of exceptionally high temperatures, turn on the air-conditioner in advance during the morning.
- Adjust the set temperature of the remote control to prevent frequent starting or stopping of the unit.

C. Condensation

When warm, moist air within the caravan meets with a cold surface, condensation water may be formed. This is also known as "sweating". In this case, make sure the following measures are taken:

- Close and seal all the doors, skylights, windows to reduce the entrance of warm moist air.
- Operate the inside fan on high fan speed, avoid low and auto fan speeds.

During the operation of the air-conditioner, condensate water will be produced and allowed to drain onto the roof. This is normal. The amount of condensate water is a function of air humidity. High humidity inside the caravan will result in more condensate being generated. Close doors, windows and hatches to reduce this to a minimum.

Please note that losses or damage caused by the condensate water are not within warranty scope.

D. Choosing and using a generator

- HOUGHTON BELAIRE requires a mains quality AC power source for correct operation. If you decide to supply power using a generator then you are strongly recommended to consult with the generator supplier to confirm suitability and sizing of the generator for your application.

Please note that losses caused to the product by the using of the generator are not within warranty scope.

Packing List

Installation parts list

Main parts:

1. BELAIRE air-conditioner outdoor unit ×1
2. Air inlet duct ×1
3. Roof mount ×1
4. Plenum mounting bracket ×1
5. Return air filter assembly ×1
6. Plenum assembly ×1

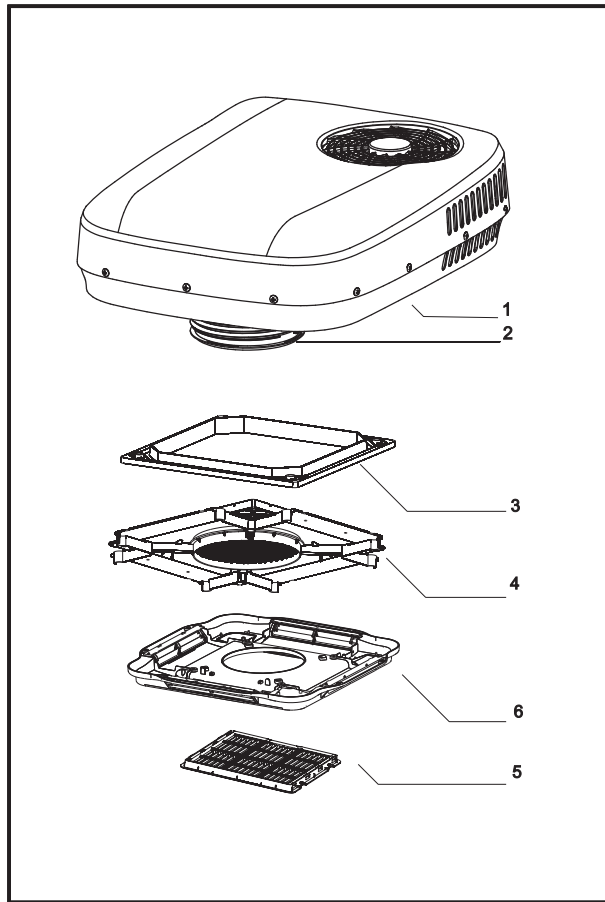

Accessories & fixing devices:

7. M8 × 120mm hex head bolts ×4
8. Metal clamping bars ×4
9. Large M8 washers ×4
10. Plenum screw –ST4.2×19 pan head screws ×4
11. Countersunk head self tapping screws ST4.2×16 ×10
12. Truss head tapping screws ST4×10 ×4

Not shown:

- Manual ×1
- Remote control & bracket ×1

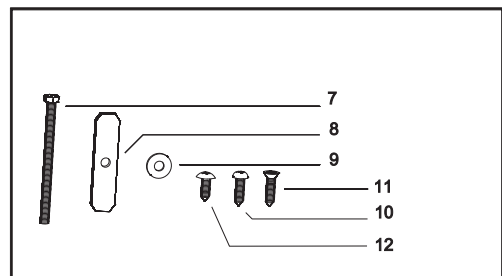

If you note that any items are missing or damaged then please contact Houghton or the local distributor.

Installation Guidance

Installation instructions

- Thoroughly read and understand this manual before installation.
- Abide by the national wiring rules in your country.
- Do not add any other parts or modify the product in the installation.
- The installers shall be equipped with refrigeration technician qualification certificates and/or suitable electrical trade qualifications.
- Consult with HOUGHTON or the local distributor in the case of unusual applications or installation conditions that are not specifically covered by this manual.

Installation requirements

- The RV or caravan roof shall be able to support the air-conditioner's weight (45kg /99 lbs).
- Minimum thickness of roof is 25mm/1"; maximum thickness of roof is 70mm/2³/₄".
- If the roof's thickness is greater than 70mm/2³/₄", you can purchase a "Thick roof kit" to suit your unit from HOUGHTON or the local distributor.

Load bearing of roof

- The roof shall be able to bear the weight of the air-conditioner and shall be level without accumulating water. It is suggested that the caravan manufacturer confirms the suitability of the roof for load bearing.
- If the installation hole is not preexisting then consult your caravan manufacturer for the most suitable way to cut the installation hole.
- The 360×360mm (400×400mm) / 14³/₁₆ × 14³/₁₆" (15³/₄ × 15³/₄") hole shall be boarded up with wood sections that are at least 20mm / ³/₄" thick. This boarding is to ensure that the roof will not crush from the installation bolts and that conditioned air does not enter the ceiling space.

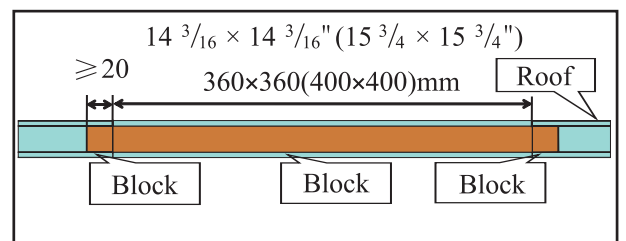
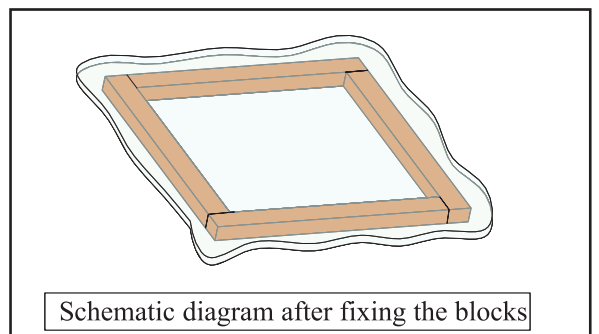
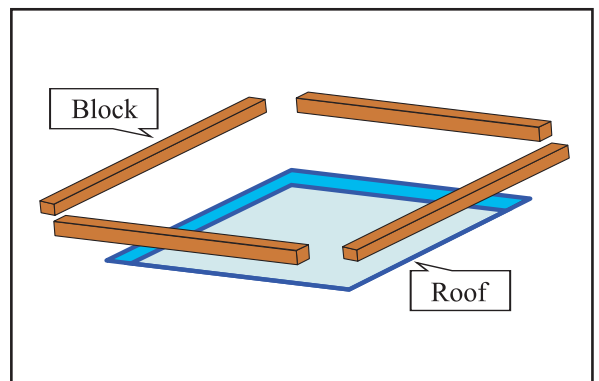

Installation position

Before the installation, consider the installation position:

- The air-conditioner shall be installed in the center of the roof to deliver even air flow within the caravan.
- The installation position of the outdoor unit shall be consistent with the traveling direction of the caravan.
- When installing ensure that there is sufficient room for the plenum assembly to be installed.
- Consider the installation position and ensure no obstructions are installed near the air outlet. A recommended distance of at least 350mm(14") should be kept.
- $360 \times 360\text{mm}$ ($400 \times 400\text{mm}$) / $14 \frac{3}{16} \times 14 \frac{3}{16}$ " ($15 \frac{3}{4} \times 15 \frac{3}{4}$ ") cutting position shall avoid roof cladding joints where ever possible.
- There shall be a space of 100mm/4" minimum all around the roof top unit to ensure suitable air flow and access for maintenance.

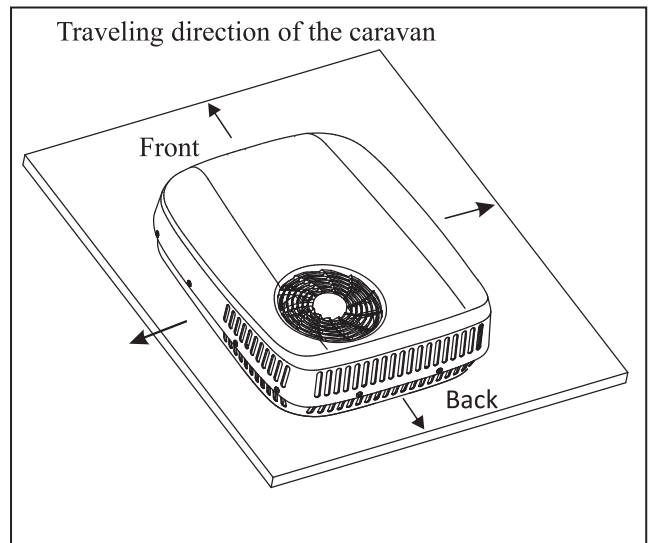

Note

Angle of inclination of the air-conditioner shall not be greater than 5° and the rear of the air-conditioner shall not be higher than the front.

For advice on installations outside of these limits please contact HOUGHTON or the local distributor.

- The figure below shows the minimum clearance distance required between the BELAIRE air-conditioner and any obstructions on the roof and the clearance required on the ceiling for the plenum installation. Measure from the reference position of the $360 \times 360\text{mm}$ ($400 \times 400\text{mm}$) / $14 \frac{3}{16} \times 14 \frac{3}{16}$ " ($15 \frac{3}{4} \times 15 \frac{3}{4}$ ") square hole. Remember to add 100mm / 4" clearance around roof top unit perimeter.

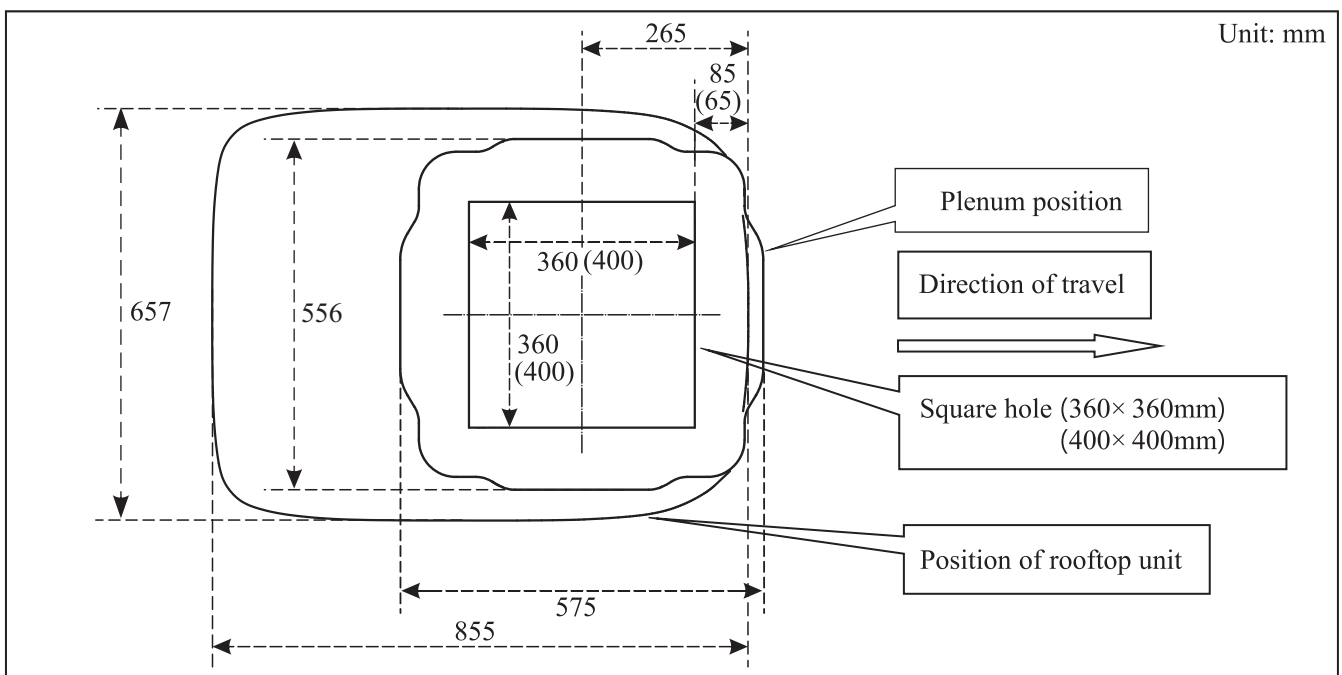

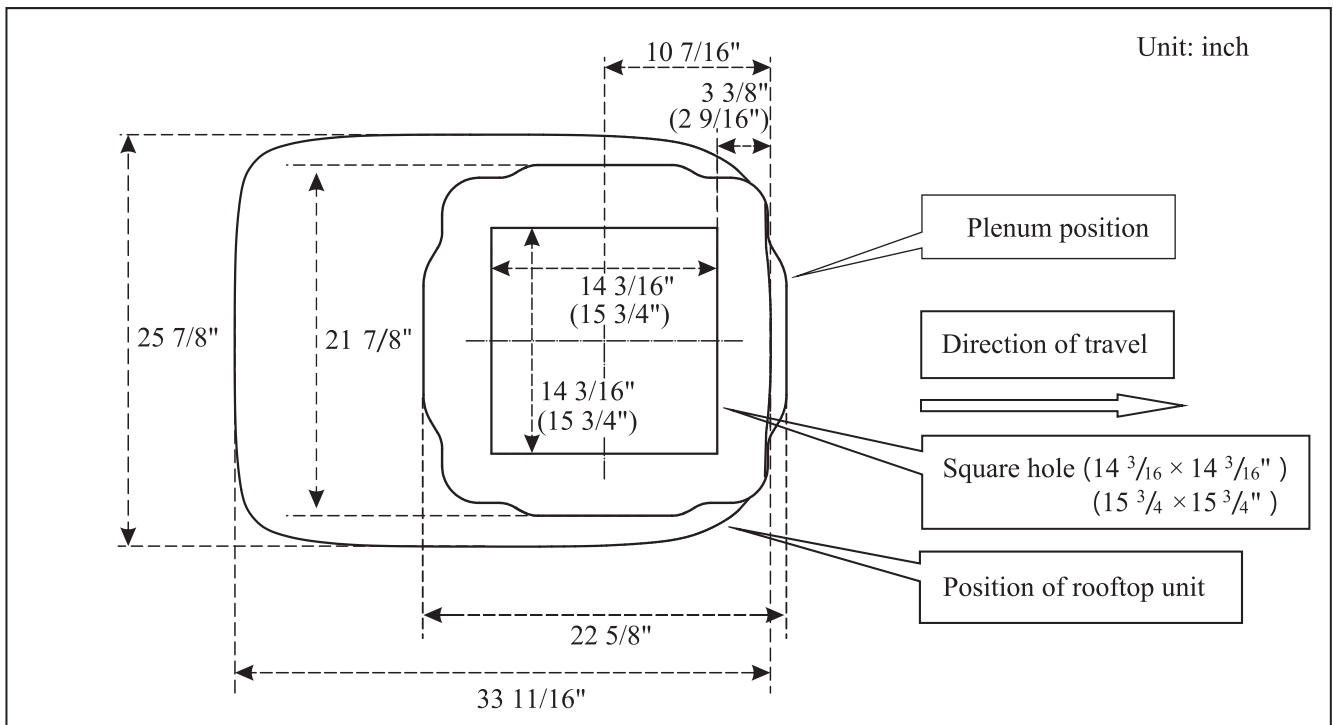

Installation of roof mount

- Make sure the roof is clean, dry and free from oil or grease.
- Confirm orientation by starting with the "This side up" label upwards.
- Turn the part over and on the reverse side of "This side up", apply self-leveling RV Roof sealant uniformly over the path shown.
- Turn the part over again and make sure "This side up" is up. Press down firmly over the installation hole and remove any sealant that has squeezed out to form an effective seal.

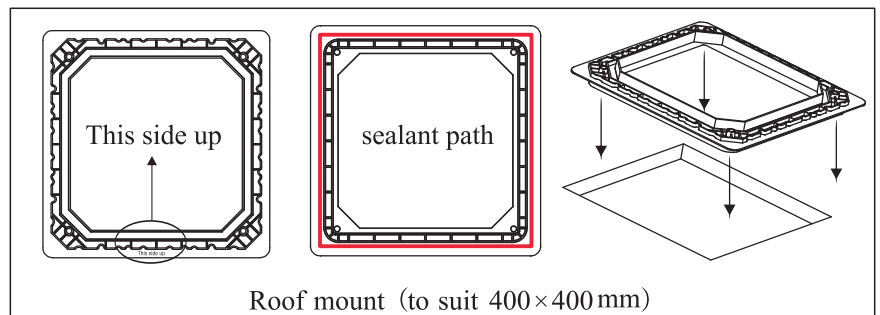
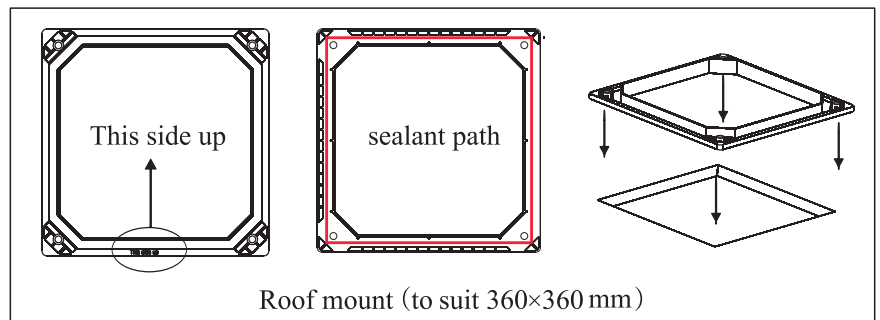

Important – do not run sealant inside the mounting bolt holes. This will cause breaks in the seal. Always run the sealant around the outside of the bolt holes as shown.

Installation of outdoor unit

- Remove the outdoor unit from the carton and move it to the installation position on the roof.
- Put the outdoor unit over the installed roof mount and adjust the position to make sure they mate and the four bolt holes on the corners align.

Note

The outdoor unit weighs about 32.5 kg / 71 lbs use appropriate manual handling precautions .
Use the M8 bolts and check if the holes are aligned with the holes of the plenum mounting bracket. If not then use a long screw driver inserted up through the two holes to assist with alignment.

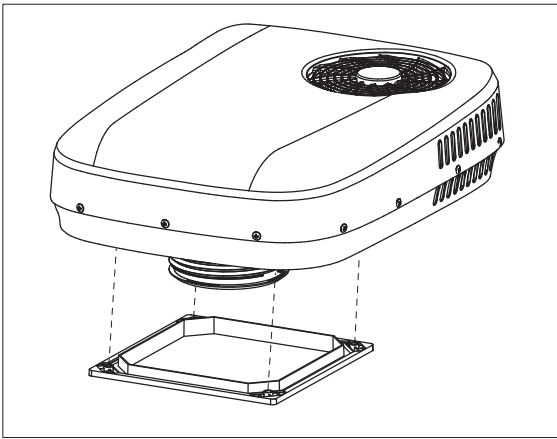

Connect the power supply

- It is the installers responsibility to ensure that local wiring regulations are followed when connecting to mains supply.
- Look upward from inside the caravan, and locate the terminal block as shown in the figure below.
- Connect the external power lines to the 3-pole terminal block and note the positions of the active, neutral and ground.

Note

Match the corresponding active, neutral and the ground wire and firmly tighten up the screws to make sure the power line is not loose or improperly connected, otherwise a short circuit or fire could be caused.

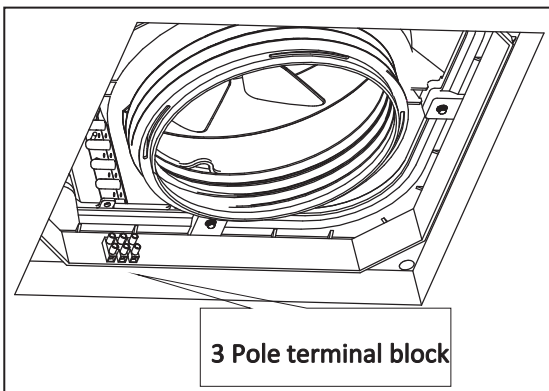

Connect the storage battery power supply (Applies to Units with LED lighting)

- Locate the pair of 12V DC supply cables (Red & Black pair). Connect these cables to the 12V DC supply from your vehicle. Connect red cable to +12V and black cable to 0V.

! DC supply shall be fused and regulated to not exceed 15V.

Connect the wall-mounted switch (Applies to Units with LED lighting)

- Locate the pair of blue wires labelled " Wall Switch " These wires can be connected to a NC or NO switch to allow for control of LED lighting via a familiar wall switch.

⊘ DO NOT APPLY VOLTAGE TO THESE LINES.

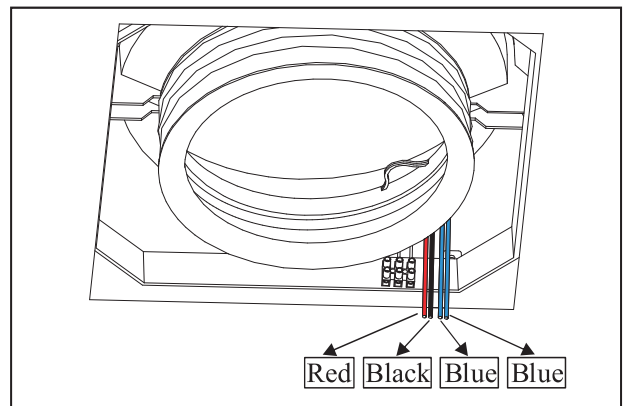

Installation of M8 bolts

- Connect M8 bolts, washers and fixing metal plates in order shown.
- Lift the plenum mounting bracket toward the air conditioner.
- Insert M8 bolts, washers and metal clamping bars into the 4 corner holes of the plenum mounting bracket. Start the bolts into their receiving threads by hand to ensure engagement.
- Ensure all bolts have started correctly for at least 2 or 3 rotations to avoid cross threading.
- Ensure the metal clamping bars align with the corresponding recess in the plenum mounting bracket as the bolts are tightened.
- Evenly tighten up all four bolts .

! Do not use Impact drivers to tighten the hold down bolts. Impact drivers will apply very high torques and damage the air-conditioner. Use only torque limited tools to tighten these bolts.

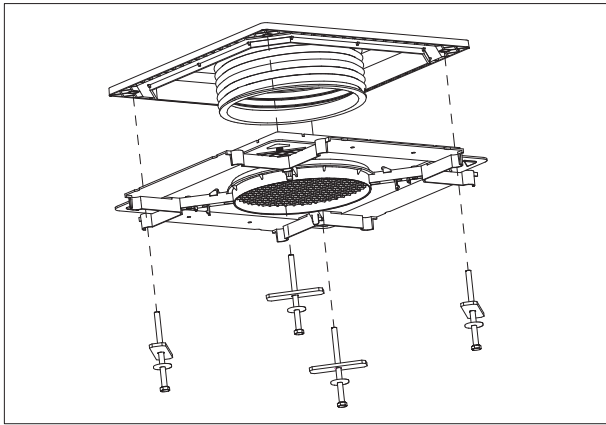

Note

Tighten the bolts to 8-10 Nm (6-8 lbf ft) torque.
Do not exceed 10Nm(8 lbf ft).

Connection of air inlet duct

- Grasp the free end of the air inlet duct and pull it down until it touches the plenum mounting bracket. Continue to pull the rim of the duct down until it engages with the four latches on the plenum mounting bracket.
- The duct is correctly connected when you hear the four distinct clicking sounds of the latches and the rim of the duct is parallel to the surface of the bracket.
- If required to fix the rim with the plenum mounting bracket using 4 ST4×10 truss head tapping screws.

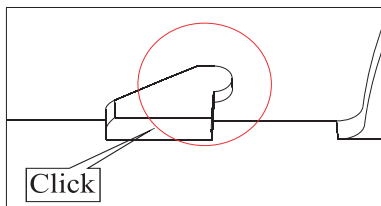
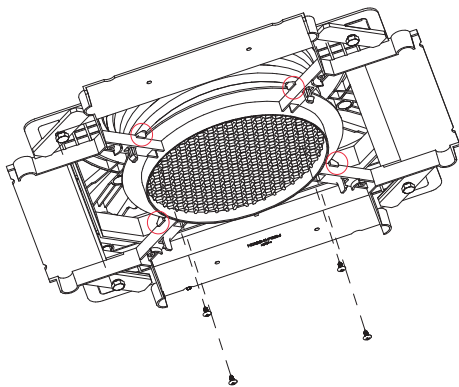

Installation of the plenum assembly

- Remove the air filter assembly from the plenum by pushing both tabs inwards and then downwards.

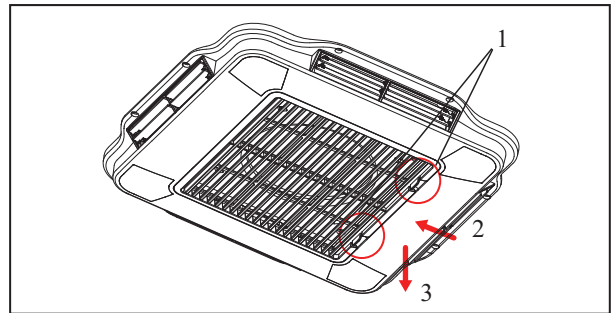

- Connect the socket and plug of the display panel. Please note that colors of the wires should be match. **(yellow to yellow, red to red, etc.)**

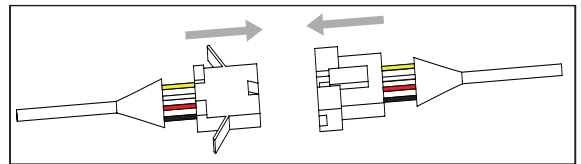

- Connect LED light power cable. (valid only for units with LED lighting)

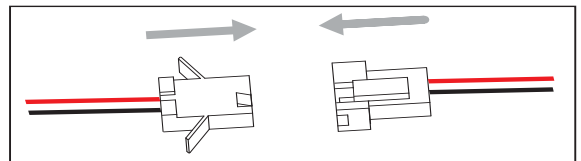

- Attach the plenum assembly to the plenum mounting bracket by engaging the two parts. You will hear four clicks to as the parts connect together.

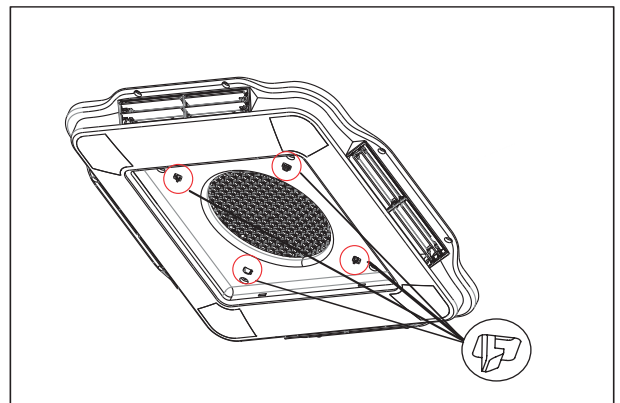

- Fix the plenum assembly on the plenum mounting bracket with four ST4.2×19 pan head screws.

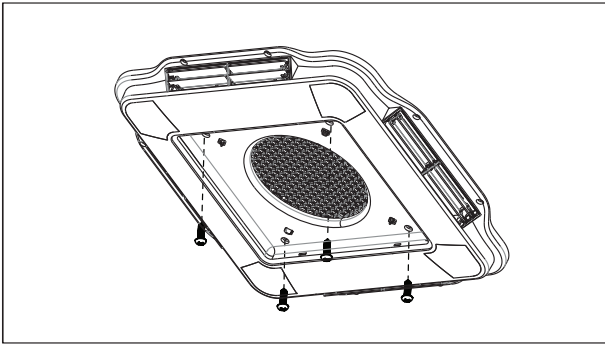

! This next section is not compulsory - if required to pull the plenum up to the ceiling and remove any gaps.

- Remove the screw caps from around the perimeter of the plenum.
- Fix the plenum to the ceiling using the 8 countersunk head screws.
- Replace the screw caps to the plenum.

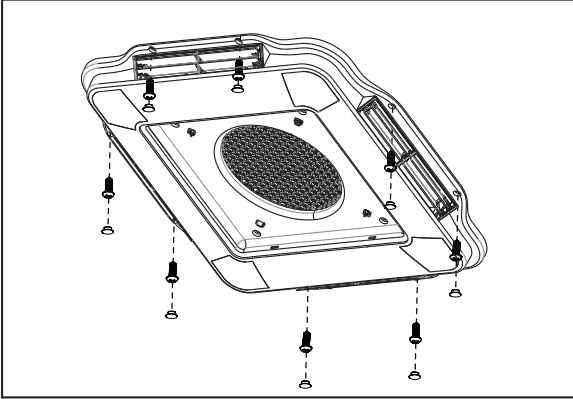

Installation of the air filter assembly

- Replace the air filter assembly as shown below.

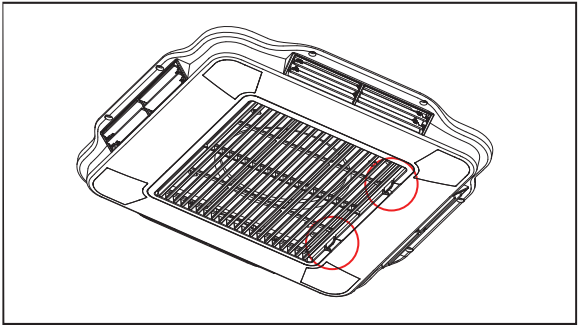
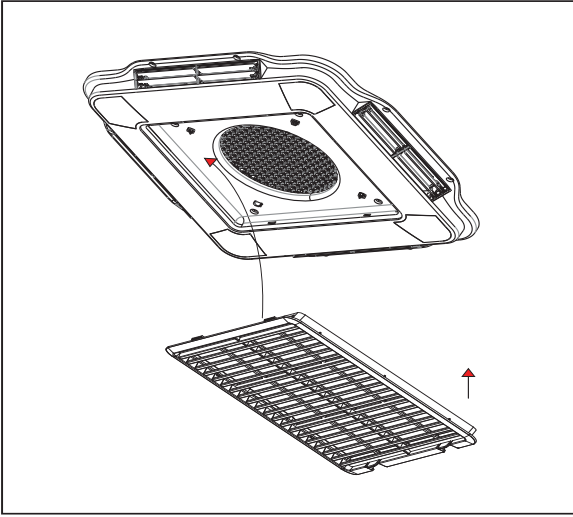

The installation is completed.

Adjust the louver

- Adjust direction and angle of louver by moving blade around its axis. The 2 blades move together. Louvers on opposite sides are symmetrical.

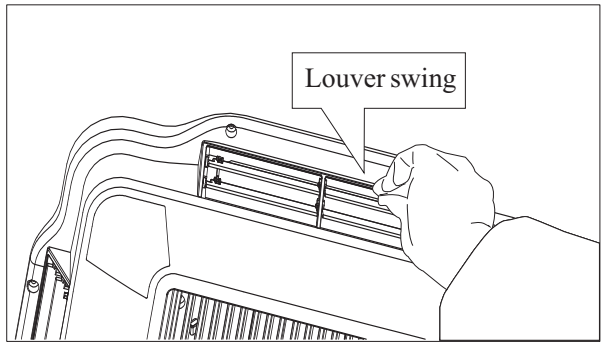

Quick Start Guide

- Switch on the power to the air-conditioner at the isolation breaker.
- Using the remote control, start the air-conditioner by pressing " ⏻ " button and then select fan function by pressing the "MODE" button.
- Operate in low FAN, medium FAN and high FAN in turn to check normal operation.
- Select COOL mode, adjust the set point temperature to three degrees lower than the room temperature, the unit will start to blow cool air after the compressor starts.
- Select HEAT mode, adjust the setting temperature to three degrees higher than the room temperature, the unit will start to blow warm air after the compressor starts.
- Press the LIGHT key, turn on /off the plenum LED light.(Valid only for units with LED lighting)
- Press the DIM key, operate in 25% brightness,50% brightness,75% brightness and 100% brightness in turn to check normal operation.(Valid only for units with LED lighting)
- Press the wall-mounted switch for LED lights to turn on or turn off the LED lights.
(valid only for units with LED lighting and wall-mounted switch)
- Turn off mains power supply turn on the remote control, select the "LIGHT" key to turn on or turn off the LEDlights . (valid only for units with LED lighting and storage battery)

Note

After selecting the COOL or HEAT mode, the compressor may delay starting for 3 minutes. This is a feature to protect the compressor.

Remote control operation

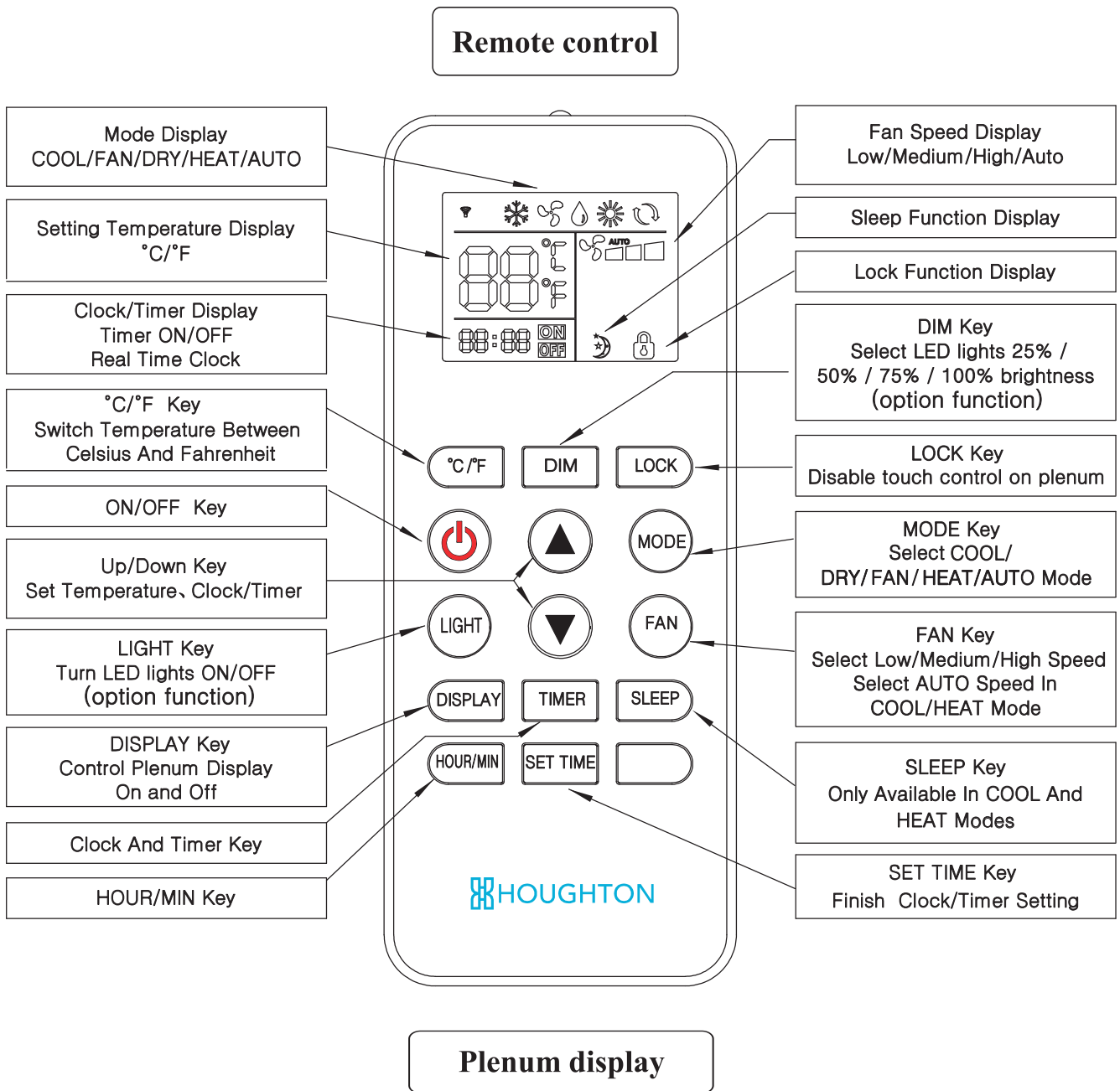



1. Operation of the remote control

Turn on

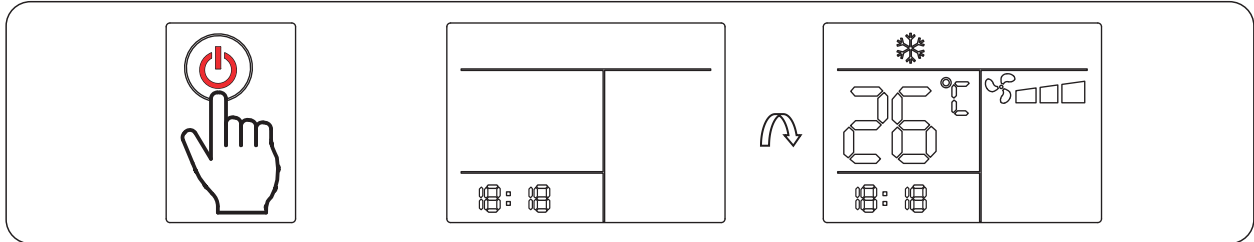
- Press the on/off "  " key, the unit turns on, the plenum buzzer beeps once and the running mode and temperature will be displayed.



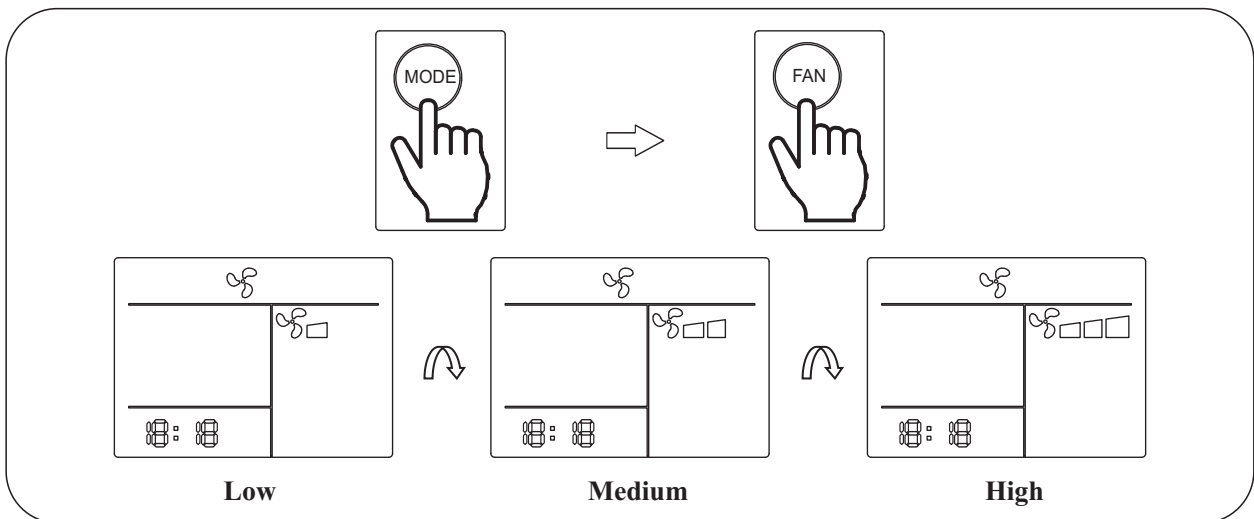

FAN mode

- Press the " MODE " key, select the "  " mode, Press the " FAN " key to select Low/Medium/High fan speeds. The plenum will display "  " and the indoor environment temperature.



COOL mode

- Press the " MODE " key, select the "  " mode. Press the down "  " key to decrease the room temperature. Press the " FAN " key to select a different speed. The plenum will display "  " and the setting temperature.

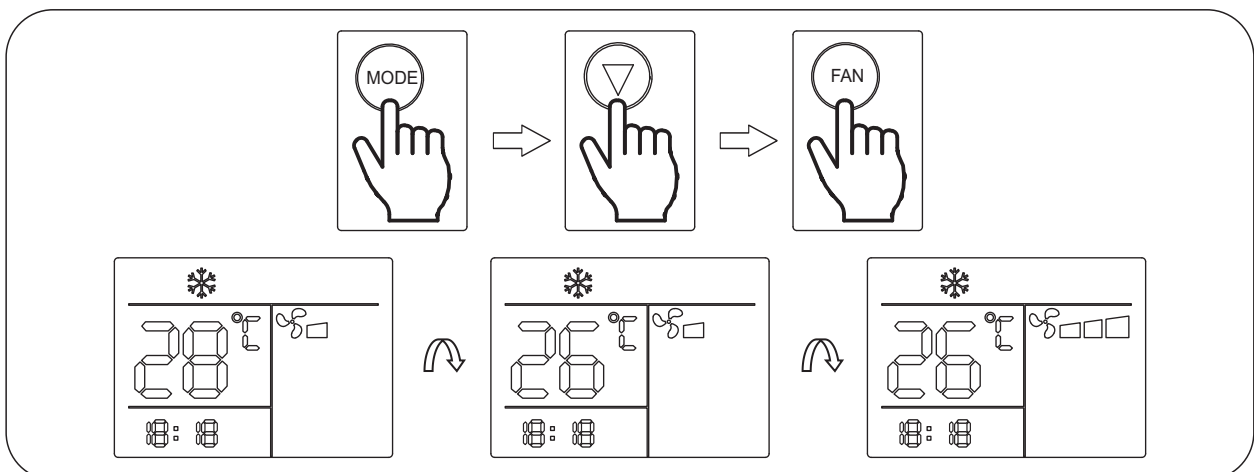

DRY mode

- Press the "MODE" key, select the "💧" mode, Press the down "▼" key to set the temperature 1°C lower than the room temperature, and the plenum will display "❄️" and the setting temperature.

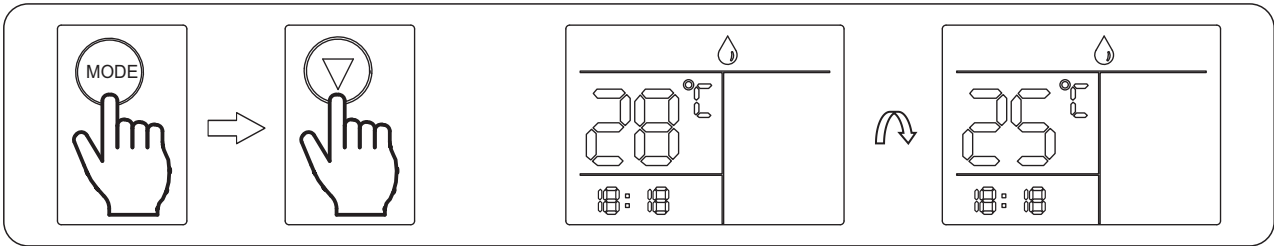

HEAT mode

- Press the "MODE" key, select the "❄️" mode. Press the up "▲" key to increase the room temperature. Press the "FAN" key to select different speed. and the plenum will display "❄️" and the setting temperature.

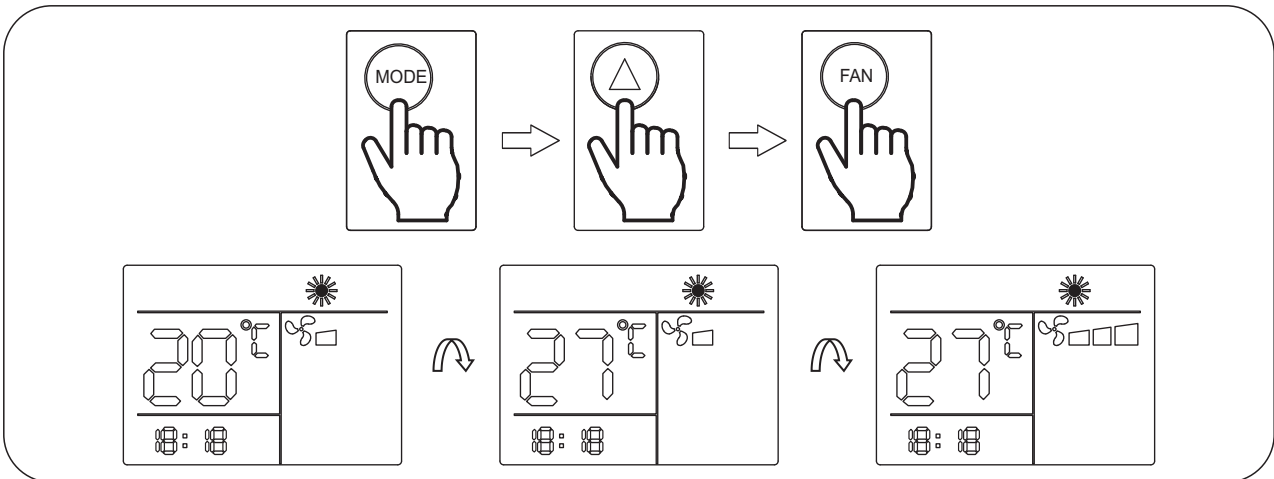

AUTO mode

- Press the "MODE" key, select the "🔄" mode. Press the up "▲" or down "▼" key to adjust the set point temperature. Press the "FAN" key to select different fan speed. The plenum will display "🔄" and "❄️" or "🔄" and "❄️" and the setting temperature.

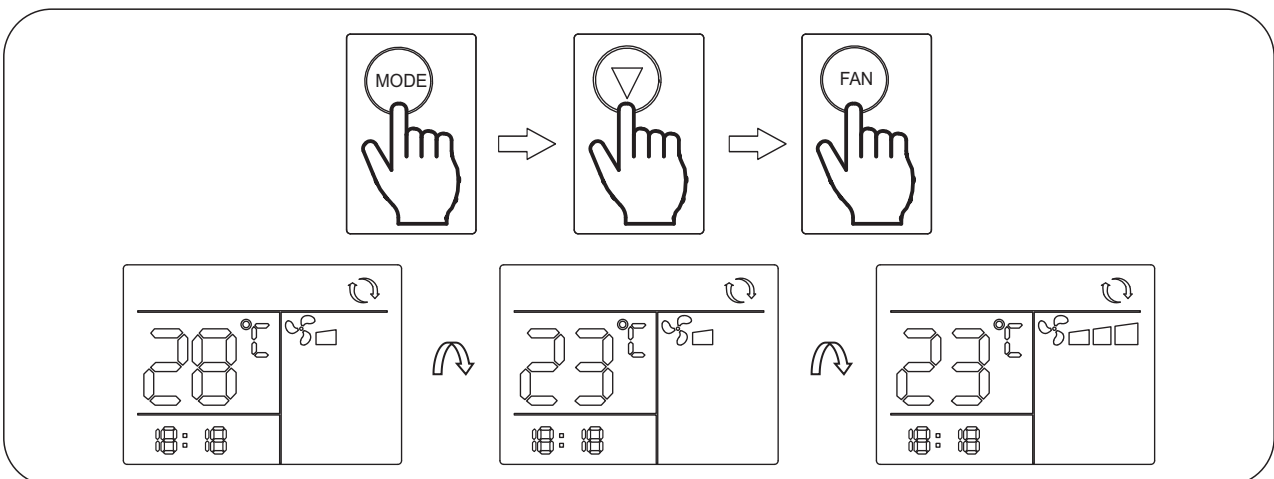

Note

When in the AUTO mode, according to the difference between the setting temperature and the environmental temperature, the plenum will display "☉" and "☼" (automatic heating), or "☉" and "☼" (automatic cooling) in the same time.

Celsius and Fahrenheit degree change

- In any mode , Press the "°C/°F " key to select temperature units of Celsius or Fahrenheit.

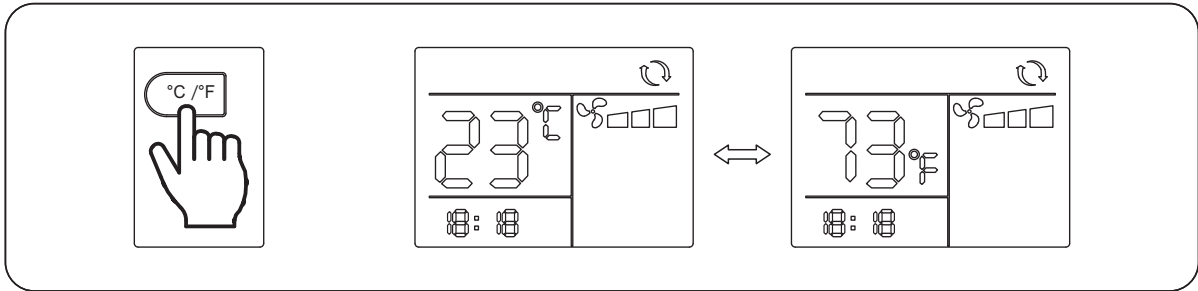

Turn off

- Press the on/off " ⏻ " key again, unit turns off and the plenum and remote control will be blank.

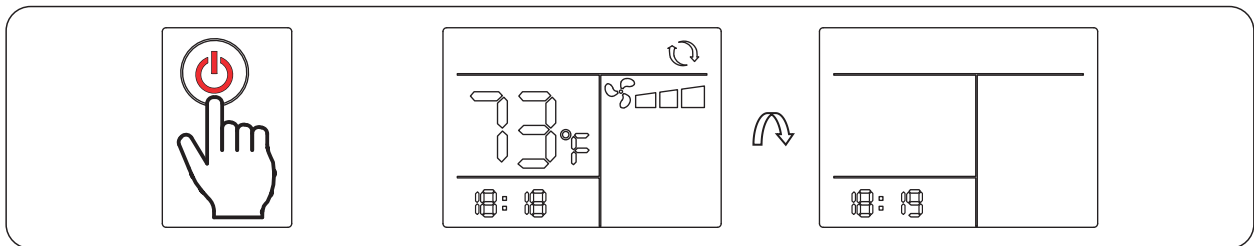

LED lighting function

- Press the " LIGHT " key, the plenum LED lighting will turn on.
- When LED lighting is on, press the " DIM " key to select 25% / 50% / 75% / 100% brightness. The plenum LED lighting will display different levels of brightness.
- Press the "LIGHT"key again, the plenum LED lighting will turn off.
- When only DC power supply, the plenum display will show "--". Only LED lighting work when the air-conditioner is in DC mode.

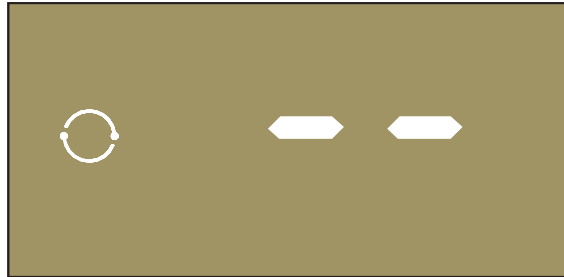

- When the DC voltage of the battery is less than 10.8 V, the LED lighting is fixed at 25% brightness and can not be adjusted. When the DC voltage of the battery returns to 11.4 V or more, the LED lighting brightness can be adjusted normally.

WIFI function (valid only for units with WIFI function)

- Turn on the remote control , enter into WIFI connection mode by pressing the "°C/F" and "LOCK" keys simultaneously for 6s. The indicator light on plenum will show " SC " and rapidly blink. Connect WIFI with mobile, open the APP, add device, click "confirm". Please refer to WIFI operation instruction for detailed instructions.

Timing function

- Set clock and timer.
 - ① Press the "SET TIME" key, the Hour digit will flash. Press "▲" or "▼" key to set hour. Press the "HOUR/MIN" key, the Minute digit will flash. Press "▲" or "▼" key to set minute. Clock setup is done.
 - ② Press the "SET TIME" key, until "ON" shows on the upper right side of the clock and hour digit flashes. Then press the "HOUR/MIN" key, and "▲" or "▼" key, to set the desired time to turn the unit on.
 - ③ Press the "SET TIME" key, until "OFF" shows on the lower right side of the clock and hour digit flashes. Then press the "HOUR/MIN" key, and "▲" or "▼" key, to set the desired time to turn the unit off.
 - ④ Clock and timer is now set. Keep on pressing the "SET TIME" key to check again clock and programmed time to turn unit on and off. When all setup is done, after 10 flashes, it will return to clock display.
- Timing to turn on : Press the "TIMER" key until "ON" flashes and shows the time to turn on. When "ON" is displayed after its 10 flashes, and only current clock is displayed, then the setup of timing to turn the unit on is done.
- Timing to turn off : Press the "TIMER" key until "OFF" flashes and shows the time to turn off. When "OFF" is displayed after its 10 flashes, and only current clock is displayed, then the setup of timing to turn the unit off is done.
- Timing to turn on and off : Press the "TIMER" key until "ON" and "OFF" flashes simultaneously and shows the time to turn off. When "On" and "OFF" are displayed after their simultaneous 10 flashes, and only current clock is displayed, then the setup of timing to turn the unit on and off is done.
- Turn off timing function: Press the "TIMER" key, when it only shows the clock, the timer function is turned off.
- Simple method to reset the timer function : remove battery from the remote control , and then replace, The remote control will be restored to the factory settings, and the timer function is turned off.

2. Plenum operation

Basic air-condition features can be accessed via the plenum control. This is useful if the remote control has been lost or is not functioning .

- Press the touch screen "☉" key on the plenum. The selected mode will cycle through "OFF ->COOL->FAN ->HEAT" modes with each touch. The set point temperature is 24°C with high fan speed.



- The plenum display will show symbols for each function:
COOL "❄️", DRY "❄️", FAN "🌀", HEAT "☀️", AUTO "☉".

Note

Operation of the air-conditioner using the plenum control can be prevented by pressing "LOCK" on the remote control. Press the "LOCK" key on the remote control again to unlock.

Tips

- The remote control should be operated by directing it towards the plenum, which will beep once when a signal is received.
- When the unit is on, press the "DISPLAY" key on the remote control, the plenum control LED display can be turned on and off.
- When the unit is on, press the "LOCK" key on the remote control to prevent operation of the plenum touch key. Press "LOCK" again to unlock this function.
- When run on heating mode in low ambient temperatures the unit will periodically defrost the outside coil. The plenum will display "dF" during defrost operation and then return to heating once the defrost is completed.
- When the ambient temperature is lower than 0°C/32°F, the heating capacity is reduced.
- If the device is left unused for long time, please remove the batteries from the remote control.
- The air-conditioner features power cut memory and automatic starting-up after power is restored.

Product Maintenance

Filter assembly

- The return air filter assembly is the only component that needs periodic maintenance.
- Check and clean the filter assembly each week when in use to prevent the filter assembly from being blocked by dirt.
- The filter assembly should be washed frequently to ensure effective cooling and heating.
- Pull out the filter assembly from the plenum by pushing both tabs inwards and then downwards.
- Lift the filter upward, then pull out the filter along air grille track.
- Clean the filter and air grille in warm water with a touch of detergent.
- Dry before replacing.

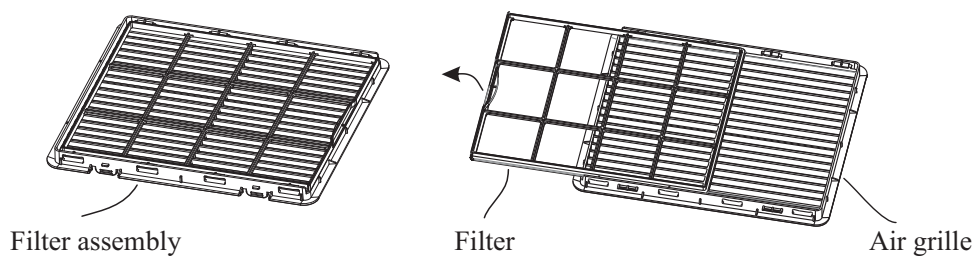

Replacement filter can be ordered separately.

Bolt check

- It is recommended that the four bolts holding the unit to the roof are checked for tightness 3 months after the first installation of the product.
- These bolts should be regularly inspected every 12 months throughout the air-conditioner's life.

Maintenance

- It is recommended that the air-conditioner is operated regularly to ensure good performance.
- In the case of a caravan that will not be used regularly then the unit should be operated for 20–30 minutes every 6 months.

Specifications

Model	H2800		
Power supply	230-240V/50Hz		
Refrigerant charged	R410A/600g		
Cooling capacity(W)	2800		
Heating capacity(W)	2600		
Power input cooling (W)	1150		
Power input heating (W)	1120		
Current cooling (A)	5.0		
Current heating (A)	4.8		
Maximum input power(W)	1430		
Maximum current (A)	6.3		
Maximum design pressure	4500kPa		
Minimum design pressure	3000kPa		
Maximum air flow	135 l/s		
Installed weight	32.5+3.0(kg)		
Outdoor unit dimension	Height 215mm/8 ³ / ₈ "	Width 657mm/25 ⁷ / ₈ "	Length 855mm/33 ¹¹ / ₁₆ "
Plenum unit dimension	Height 49mm/ 1 ¹⁵ / ₁₆ "	Width 556mm/21 ⁷ / ₈ "	Length 575mm/22 ⁵ / ₈ "

Notes

1. All parameters listed are subject to change without notice and the specifications shown on unit data plates shall prevail.
2. E&OE. All values are approximate & subject to change.
3. Rated cooling test condition: indoor 27°C/19°C outdoor 35°C/24°C;
Rated heating test condition: indoor 20°C/12°C outdoor 7°C/6°C.

Exploded Diagram and Parts List

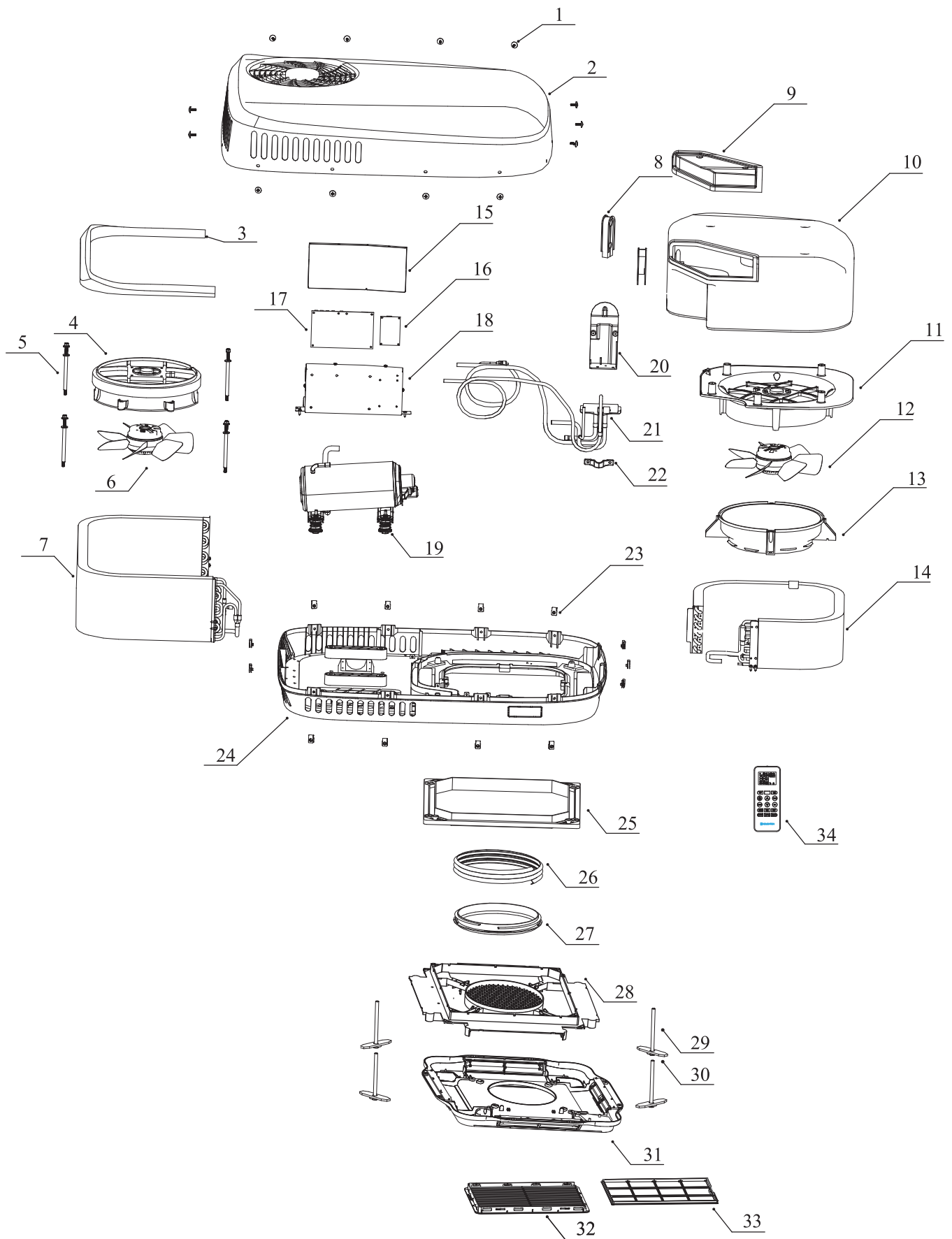

No.	Figure No.	Name	Qty
1	18-12-13	Mushroom head screw, white, M5	13
2	7488-1000-01	Canopy	1
3	4768-1060-01	Condenser insulating layer	1
4	4728-1000-07	External fan motor bracket	1
5	4728-1000-13	Outside fan mounting studs	4
6	4778-1700-27	Outside fan	1
7	4778-1521-00	Condenser components	1
8	4708-1000-15	Pipe clamp	2
9	4768-1000-03	Evaporator housing plastic cover	1
10	4768-1050-01	Evaporator housing	1
11	4768-1020-01	Internal fan motor bracket 1	1
12	4778-1700-26	Inside fan	1
13	4768-1020-02	Internal fan motor bracket 2	1
14	4778-1511-00	Evaporator components	1
15	4768-1000-10	Electronic box lid	1
16	4768-1700-14	Power control board	1(with LED lighting)
17	4708-1241-01(f)	Electronic control board	1
	4768-1241-01	Electronic control board	1(with LED lighting)
18	4768-1700-01WB	Electronic box	1
19	7488-1000-06	Compressor	1
20	4768-1000-03	Worm shell plastic parts	1
21	7488-1500-00	Four-way valve components	1
22	4708-1230-06	Pipe bracket	1
23	4638-1000-10	B type plate spring nut	13
24	4768-1000-02	Base (with inserts)	1
25	4709-1000-07	Roof mount (to suit 360x360)	1
	4709-1000-07(E)	Roof mount (to suit 400 x400)	1
26	4709-0000-04	Air duct	1
27	4838-0000-12	Air duct loop 3	1
28	4709-0000-02	Plenum mounting bracket	1
29	18-10-59	M8 hex head bolt (M8*120)	4
30	4709-1100-01	Fixing metal plate	4
31	7489-1000-01X	Plenum assembly	1
	7489-1000-01AX	Plenum assembly	1(with LED lighting)
32	4709-1000-10	Air grille	1
33	4709-1000-04(X)	Filter	1
34	7339-1700-02(GG)	Remote control	1
	7339-1700-02(LED)	Remote control	1(with LED lighting)

Trouble Shooting Guide

No plenum display when unit turned ON

- Check whether the power is supplied to RV and circuit breakers are on?
- Check that the remote battery is OK?
- Check whether the remote control is off?

Cooling not available

- Check that the cooling mode is selected and the plenum display shows " ❄️ ".
- Use the remote control to set required temperature below the current room temperature.
- The compressor will delay a re-start for three minutes.

Heating not available

- Check that the heating mode is selected and the plenum display shows " 🔥 ".
- Use the remote control to set required temperature above the current room temperature.
- More time would be needed for starting heating under extremely cold condition.
- When the unit is in heating mode and the outside temperature is very low the unit may automatically enter defrost mode. The heating will temporarily stop as the unit warms the outside coil to remove any frost & ice. Heating will resume once the outside coil has been cleared. During defrost the unit will display " dF " .

Poor cooling capacity

- To make sure the filter is clean.
- Turn on the fan to high FAN to obtain the maximum capacity.

- To make sure all the doors and windows, as well as the sunroof are closed.
- Curtains and awnings can be used to decrease the heating load.

Fault codes displayed on the panel

Communication fault	E0
Room temperature sensor fault	E1
Indoor coil temperature sensor fault	E2
Outdoor coil temperature sensor fault	E3
No cooling effect	E4
Outdoor coil temperature too high	E5

- In case there is " 0 " or a jumbled display while on generator supply this may indicate unstable voltage and current.

Before contacting Houghton for technical support please collect the following information.

- Are any error codes displayed?
- Is the display panel in normal operation or not? Does it display a temperature from 16 to 30 °C?
- Can you adjust the setting temperature when in cool or heat mode?
- Is there a " 0 " shown in the display?
- Is the display showing a jumbled display?
- When in fan mode is there any air flow from the plenum outlets?
- Can you hear the compressor starting or stopping in heating or cooling mode?

Your help in collecting this information will greatly assist the Houghton service team in correcting any problems - Thank you.

Circuit Diagram

